

Takara Belmont Barber Chair

# LUAR

Model No. AB-MF

## Operation Manual

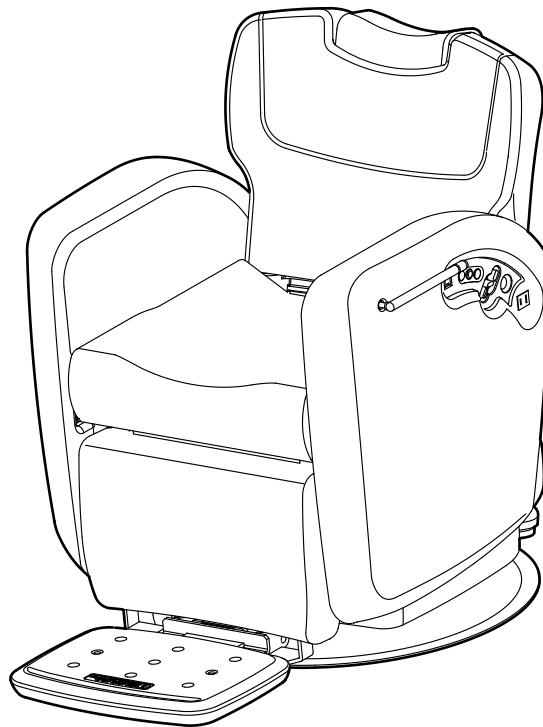

Thank you for purchasing this Takara Belmont product.

Be sure to read this operation manual before operating the chair and always operate the chair properly according to the instructions herein.

Failure to read this operation manual may lead to accidents.

- Carefully store this operation manual in a secure location near this product where they can be readily accessed, and refer to them whenever necessary.
- This product is a barber chair designed for the services offered at hair salons. Do not use this product for any purposes other than those described above. This product shall be operated only by qualified hairdressers.
- Ask your authorized Takara Belmont dealer to install this product.

Please contact Takara Belmont with the BOOK No. (outlined below) if this operation manual becomes torn or damaged and unreadable, or is lost.

# Contents

<b>Explanation of Warning Labels</b>	<b>3</b>
<b>Safety Precautions</b>	<b>4</b>
<b>Use Precautions</b>	<b>10</b>
<b>Affixing Locations of Warning Labels</b>	<b>11</b>
<b>Precautions Related to Synthetic (Natural) Leather</b>	<b>12</b>
<b>Accessories</b>	<b>12</b>
<b>Part Names</b>	<b>13</b>
<b>Preparation</b>	<b>15</b>
<b>Use Procedures</b>	
(1) Guiding Customers .....	16
(2) Raising/Lowering the Chair .....	18
(3) Reclining and Raising the Backrest .....	19
(4) Using Preset Function .....	22
(5) Removable Footrest .....	26
(6) Heater .....	27
(7) Accumulator (OS Type) .....	27
(8) Yume Swing Bowl Positioning (OS Type) .....	28
(9) Dryer/Iron Holder (AB-MFB) .....	29
(10) Service Outlets (Type C Specification) .....	30
(11) Rotating Table (OS Type) .....	31
(12) Foot Cushion (OS Type) .....	32
<b>Cleaning Procedures</b>	<b>33</b>
<b>Before Requesting Repair</b>	<b>34</b>
<b>Daily Inspection</b>	<b>35</b>
<b>Specifications</b>	<b>37</b>
<b>Standard Use Period</b>	<b>38</b>
<b>Disposing of this Product</b>	<b>38</b>
<b>Declaration of Conformity</b>	<b>38</b>
<b>Intended use of the product</b>	<b>38</b>

# Explanation of Warning Labels

## ■ Before Use

Be sure to thoroughly read these warnings related to safety and operate the chair accordingly in a safe manner.

## ■ User Prohibitions of this Product

Only persons who are certified hairdressers or beauticians can be allowed to use this chair.



## ■ About the Precautions Listed Here

The precautions continued herein are in order to ensure safe use, and to prevent any injury to users and other persons, and to prevent any damage.





The precautions are categorized into "WARNING" and "CAUTION" according to the level of hazard and damage and the degree of urgency which may occur if the product is used improperly. To ensure safety, adhere to these precautions at all times.

Takara Belmont has absolutely no responsibility for accidents that might be caused by failure to obey "Safety Precautions" and "Use Precautions" resulting in injury to users and other persons, or other damage. In this case, those using the product without observing "Safety Precautions" (and "Precautions for Use") will be responsible for these hazards and damages.

A detailed explanation of the cautionary symbols is provided below. Be sure that you fully understand their contents before reading the rest of this manual.

Classification of Precautions	Level of Harm and Damage, and Degree of Urgency
 <b>WARNING</b>	This indicates that failure to obey the corresponding warning and the resulting improper operation can result in death or serious injury.
 <b>CAUTION</b>	This indicates that failure to obey the corresponding warning and the resulting improper operation can result in mild injury, or moderate harm and damage.

The following symbols are used to describe specific indications that you must obey.

Prohibited Action Symbol	Mandatory Action Symbol
 Indicates generally prohibited actions.	 Indicates actions by general users that must be performed.
 Indicates that disassembly, repair and modification are prohibited.	 Indicates that the power plug must be removed from the socket.

# Safety Precautions

## WARNING

### Power Plug and Cord



**Do not connect the earth (ground) to the following objects.**

- Water pipes  
(Complete grounding is not possible as hard plastic pipes are widely used.)
- Gas pipes (Can result in an explosion or fire)
- Lightning rods and telephone dedicated grounding wire (Dangerous during lightning)

**Do not touch the power plug, outlet or power switch with wet hand.**

Touching the power plug, outlet or power switch with a wet hand can result in electric shock.



**Use an unshared outlet that has an attached ground terminal and matches the rated voltage and current \*of this product.**

Using the same outlet together with the power plug of other devices can result in abnormal heat generation and possible fire.

\* 230V AC (12 A or more).

**Firmly insert the power plug into the outlet.**

Be sure to fully insert the power plug into the outlet until reaching the base of the plug.

Failure to fully insert the plug or similar fault can result in a short circuit or heat generation that causes a fire.

**If there is dust on the power plug or wall outlet, wipe it well with a dry cloth.**

Continued use may cause fire.

**Hold by the power plug when unplugging.**

Do not pull the cord to remove the power plug from the outlet. Hold by the power plug at the end of the cord when removing. Removing the plug by pulling the power cord can damage the power cord, resulting in electric shock or fire.

**Handle the power cord with care.**

Damage to the power cord may result in electric shock or fire.

- Do not damage the cord.
- Do not place anything on the cord.
- Do not tamper with the cord.
- Do not heat the cord.
- Do not forcibly bend, twist, or pull the cord.

**Be careful of power cord or plug breakage.**

Do not use any power cord or plug that is damaged, or that fits loosely when inserted into an outlet. Doing so can result in electric shock or fire.

**Power cord replacement must be performed by a qualified person.**

If the power cord is damaged, it must be replaced by Takara Belmont, its distributors or similarly qualified persons in order to avoid a hazard.

**Securely connect to ground.**

Failure to make a ground connection can result in electric shock if there is a malfunction or short circuit. Consult an electrician for grounding procedures.



**Unplug the power plug when the chair is not in use.**

Turn off the power switch and remove the power plug from the outlet when the chair is not to be used for a long period of time, such as at the end of work or during holidays.

Unexpected operation can result in an accident or fire from a short circuit due to insulation aging.

### Installation/Transport



**Installation precautions**

- Ask your authorized Takara Belmont dealer to install this product.
- The chair must be installed on a perfectly flat and solid floor.  
Installing the chair to a non-flat floor can result in the chair tipping over.

# Safety Precautions

## WARNING

### Use and Cleaning Precautions



**Be careful to keep hands, fingers and other body parts of the customer and user from touching or getting close to moving parts.**

Doing so may cause the unit to have them pinched, resulting in injury.

**Customer must not lie on his/her stomach, put his/her legs or feet on the seat, or sit on the product with a child in his/her arms.**

The chair may move unexpectedly, causing injury.

**Not getting on the front edge of the seat or footrest.**

The chair may fall or move unexpectedly, causing injury or damage to peripheral devices or facilities.

**Not sitting on or applying excessive load to any place other than the designated place.**

Do not sit on or apply excessive load to headrest, armrests, backrest, legrest, or footrest.

Failure to do so may cause injuries due to the product falling over or damage to peripheral equipment or facilities.

**Do not wash the chair by pouring water on it.**

Washing in such a manner can result in a malfunction or electric shock.



**Do not disassemble, repair or modify the chair.**

- Disassembly or repair must only be done by a qualified service staff. Disassembly by yourself can result in an accident, a malfunction, electric shock or fire.

- Never modify this product. Doing so is dangerous.



**Precautions when seating customers.**

- As shown in the figure, instruct the customers to sit on the chair.

Ensure that the customers maintains the posture shown in the figure before operating the chair.

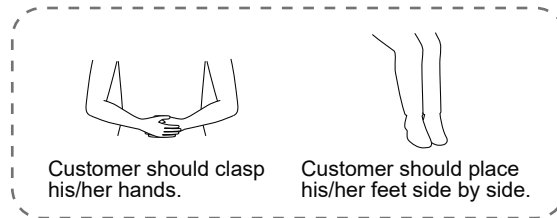

- For small children, when raising the backrest, the hips should be shifted to the correct position in the seat.

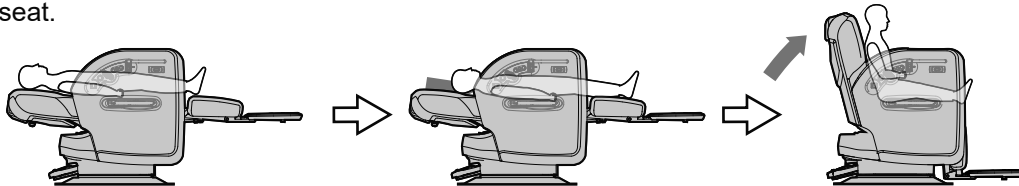

**Remove customers glasses and accessories (necklaces, bracelets, etc.) before services as they may interfere with hairdresser or cause injury.**

**Precautions regarding customers and children**

- Be careful to closely watch customers when using this chair. Customers (especially children) may touch the control switch inadvertently, leading to an unexpected accident due to incorrect operation of the product.

- This appliance can be used by children aged from 8 years and above and persons with reduced physical, sensory or mental capabilities or lack of experience and knowledge if they have been given supervision or instruction concerning use of the appliance in a safe way and understand the hazards involved.

- Children shall not play with the appliance.

- Cleaning and user maintenance shall not be made by children without supervision.

# Safety Precautions



## Use and Cleaning Precautions



### **Precautions when getting in and out of the chair**

- When the customer gets on or off the chair, the chair should always be at entry/exit position (auto return position) with the chair rotation locked.
- Before moving the customer from a wheelchair to chair or vice versa, ensure that not to place the wheelchair within operation range. Contact of the feet or the wheelchair casters with obstacles (such as foot switch) may cause sudden move of the chair, leading to injury or damage to peripheral equipment and devices.
- When the customer is moved from a wheelchair to chair or vice versa, he/she or the chair must be carefully monitored to prevent falling.
- If the customer has to get off chair at a position - due to power failure or in the event of an emergency - other than the designated position for getting on and off chair, he/she or the chair must be carefully monitored to prevent falling.

### **Precautions when reclining/raising the backrest**

- When raising/reclining the backrest, make sure that there are no hand or fingers of the customer between the backrest and the body/seat.
- Carefully recline the backrest so that the headrest or backrest will not contact any shampoo bowl or nearby equipment.
- When the backrest is laid down, the body lowers in conjunction with it. Be careful not to pinch your body or objects under the body or between the body and the pump cover.

### **Precautions for chair operation**

- Before operating the chair and during operation, thoroughly check that there are no bodies or limbs of persons, or possible obstacles in the operating range of the chair (ranges of seat raising/lowering, backrest reclining/raising, legrest operating directions, and seat rotation) or nearby. It may become caught in the chair, causing injury or damage to peripheral equipment or facilities.
- When operating the product, make sure that the customer is sitting in the correct posture and position, and keep an eye on the customer during operation.  
Especially, when an elderly customer or a small child is sitting down, the operation may be unexpectedly burdensome due to the posture change caused by the auto operation. Stop the operation immediately if you feel any abnormal changes.

### **Precautions during chair rotation**

- Make sure that no persons or objects are nearby before slowly rotating the chair.
- When the backrest is fully reclined, rotate it with attention to the position in which the customer is lying and the posture of his/her body and limbs.
- After rotation, be sure to lock the chair base.

### **Caution when raising and lowering the legrest**

- When raising the legrest, make sure that customer's toes or the footrest does not come in contact with peripheral equipment.
- When lowering the legrest, make sure that there is no person or object under the legrest or footrest.

### **Precautions when removing/installing the footrest**

- After installing the footrest, make sure that the footrest bracket is firmly hooked to the footrest mount and that the footrest is kept level. Failure to do so may result in injury.
- Be careful when lifting and carrying the footrest, and of where you place it because the footrest is heavy. Dropping the footrest could result in injury or damage the floor.

# Safety Precautions



## Use and Cleaning Precautions



### Precautions for the service outlets

- Be sure to fully insert the power plug of the device being used into the outlet until reaching the base of the plug. Failure to fully insert the plug or similar loose connection can result in a short circuit or heat generation that causes a fire.
- If the connection becomes loose, immediately stop using the equipment attached to the service outlet and unplug the equipment from the service outlet. Contact your authorized Takara Belmont dealer as soon as possible for inspection or replacement parts.
- Remove the power plug of a device from the outlet when not using it.
- If any water gets on a service outlet, immediately turn off the chair power switch, remove the plug, and wipe away the water. Additionally, if a substantial amount of water gets inside a service outlet, immediately remove the plug and contact your authorized Takara Belmont dealer.
- Do not touch a service outlet with a wet hand.
- If needed, use a suitable conversion adapter as 12A or higher.
- When a conversion adapter is used, make sure that it is firmly plugged into the service outlet. Loose connection can make the adapter heated up and lead to fire.

### Precautions when using the heater

- Be sure to turn off the heater switch when not necessary. Using the heater for an extended period causes the temperature to increase, possibly resulting in burns or fire.
- Do not use the heater for a long time. Doing so may cause low-temperature burns. Should red spots or blister occur, immediately take the diagnosis of a medical specialist.
- If you notice abnormal heat when using the heater, turn off the power switch, unplug the equipment, and contact your authorized Takara Belmont dealer.

### Precautions when using in an environment where electromagnetic waves exist

Do not install the chair near equipment that generates electromagnetic waves such as communication equipment and elevators. Do not use devices that generate electromagnetic waves near this chair. Doing so can result in faulty operation.

### Be sure to always perform daily inspection.

Failure to do so may result in injury or damage to peripheral equipment or facilities. Refer to "Daily Inspection" on p35-36.

### Stop using the product if it fails.

If the product should fail, stop using it immediately, turn off the power switch, disconnect the power plug, and contact your authorized Takara Belmont dealer for repair.



### Turn off the power switch and unplug the power plug before cleaning.

Failure to do so can result in electric shock or fire. Unexpected activation of the product may cause injury.

### Procedures if a power outage occurs

Turn off the power switch and remove the power plug of this product from the outlet in order to prevent unexpected operation when recovering from a power outage. Also turn off the power switches of all devices connected to the service outlet and remove the power plugs of devices.

# Safety Precautions



## Use and Cleaning Precautions



**Do not allow any person whose weight exceeds 135 kg to sit in the chair.**

Doing so can cause the chair to tip over or faulty operation.



**Ensure that each part works properly before use.**

Be constantly careful of and inspect for looseness, rattling, tilting, vibration, noise, temperature, odors and other possible problems. If you feel that something seems slightly different or not normal, immediately stop using the chair, turn off the power and unplug the power plug, and contact your authorized Takara Belmont dealer.

**Always be sure to use your hands to operate the switches.**

Be sure to operate the switch by hand, except for the foot-operated switch. Operation with other than hands may cause damage or unexpected operation.

**Be extremely careful not to mistake the switches when operating.**

Pay full attention to the surroundings and advise the customer before operation of the expected chair movement to avoid any injury.

**Precautions when using the headrest**

- Wipe off all water and chemicals immediately if any gets on the headrest bar. Failure to do so can prevent the headrest from being securely fixed because of corrosion or degradation of friction force due to rust.
- Be careful when operating the headrest that fingers and other body parts are not pinched between the area around the operating lever or in between the headrest and backrest.
- Be careful not to catch customer's hair or clothing when storing the headrest.

**Precautions when using the cape holder**

- Be sure to store the cape holder when it is not used.
- When storing the cape holder, be careful not to get your or the user's fingers caught between the armrest and the cape holder.
- Use of the cape holder beyond its load capacity 10N(1kgf) may result in damage or injury, etc.

**Precautions when adjusting the footrest adjuster**

When adjusting the height of the adjuster, make sure that the adjuster does not rub on the floor or catch the power cord when the chair is rotated. On the contrary, adjust the height so that the product does not fall over even if the customer gets on the footrest at exit/entry position.

**Precautions when using the dryer/iron holder**

- Be careful not to let the operator's feet come in contact with the dryer/iron holder.
- Use of the dryer/iron holder beyond its load capacity 50N(5kgf) may result in damage or injury.

**Precautions when using a rotating table**

- Check that the table is securely inserted into the table securing slot before using the table. Failure to fully insert the table can result in the table falling off, causing injury and damage.
- Always be sure to pull out and carry the rotating table with both hands as it is heavy, and store it in a stable location. Accidentally dropping the table could result in serious injury.
- Be careful when using the rotating table that the customer's fingers or hands do not interfere with the table when raising the backrest.
- Immediately wipe off any chemical solutions that spill on the table.
- Be careful when rotating the rotating table that the customer's fingers or hands do not interfere with the table.
- Be careful that nearby devices such as the bowl do not interfere with the table when rotating or operating the chair while using the table.



# Safety Precautions



## CAUTION

### Use and Cleaning Precautions



#### **Precautions when using a foot cushion**

Remove the foot cushion from the footrest when the customer gets in and out of the chair. Otherwise the customer may fall over causing injury.

#### **Be careful not to trip on the power cord.**

It may cause injury.

#### **Immediately wipe off any chemical solutions or water that spills on the chair.**

Water or chemical adhering to a service outlet or control panel can result in faulty operation or a short circuit. Immediately turn off the power switch, and wipe off any chemical or water that has adhered to the product by using a dry soft cloth.

#### **Precautions for cleaning procedures**

The metal and mechanical parts of the chair have sharp edges. Be careful when cleaning the chair that your hands, fingers or other body parts are not injured.

#### **Turn off the power switch at the end of day or during recess.**

Injury or damage may result from operation due to unexpected contact.

# Use Precautions

**Immediately wipe off any chemical that spills on the chair.**

Failure to do so can result in deformation or discoloration.

**Do not apply heat**

Doing so can result in deformation or discoloration.

**Discoloration of resin**

Resin materials are used in external components of this product. Carefully selected materials are used; however, discoloration may occur for reasons such as natural deterioration or the adherence of solutions. To ensure use of the product for longer period, immediately wipe off any solutions if it adheres, and avoid sunlight.

**Do not place any objects other than persons in the seat.**

Other objects can result in deformation or tearing of the leather, or corrosion.

**Do not strongly strike or scrape the chair.**

Doing so can result in damage, and faulty operation.

**Do not push the backrest forward.**

This may cause malfunction.

**Recline the backrest at the end of the day**

When you have finished working for the day, lower the chair to the lowest position and completely recline the backrest. This helps to extend the service life of the chair by not applying a load to springs and cylinders.

**Do not use this chair for any applications other than hairdressing/beauty-related procedures.**

This product is designed for commercial use in barber shops and beauty salons.

Only persons who are certified hairdressers or beauticians can be allowed to use this chair.

**Do not use or store outdoors.**

Doing so can result in damage.

**Contact your authorized Takara Belmont dealer if the breaker function (p. 34) frequently operates.**

**Maximum load (maximum lifting capacity) is 1350 N (135 kgf).**

The lifting speed of the chair may change or the operation noise may increase depending on the weight of the customer.

# Affixing Locations of Warning Labels

## Rotating Table (OS Type)

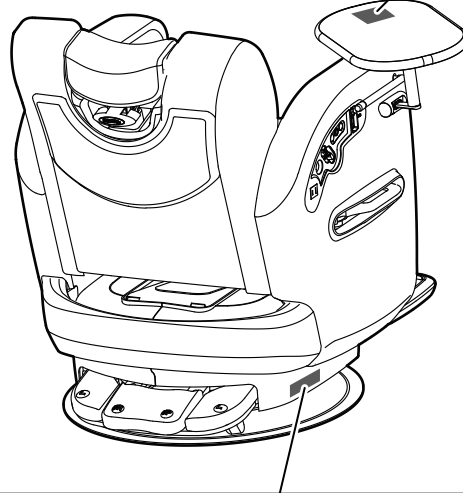

### ⚠ CAUTION

- Do not weigh more than 5kg on the table.
- Insert the table tightly into the slot, when using the table.
- Careful with customer's fingers or hands not to touch the table when set back the chair.
- Wipe off the table immediately, if any solution attaches.
- Use both bands when handling the table. The table weighs 3kg.
- Rotate and activate the chair with caution while using the table. Do not let the table touch the bowls or other equipment.

### ⚠ WARNING / AVERTISSEMENT

Risk of pinching during the operation. Check the space below and around the chair when raising or lowering the chair and the legrest.

Risque de pincement durant l'opération. Vérifier l'espace en dessous et autour de la chaise lors de l'élévation ou de la descente de la chaise ainsi que du repose jambes.

Risk of dropping of the pump. Carry the chair with holding the base and the foot pedal.

Risque d'échapper la pompe. Transporter la chaise en soutenant la base et la pédale.

Risk of malfunction or a fire caused by a short circuit. Unplug the power cord when not used.

Risque de malfonction ou incendie causée par un court-circuit. Débrancher le cordon d'alimentation lorsque non-utilisé.

Risk of electric shock, fire, and abnormal motion. Do not disassemble, repair or modify.

Risque de choc électrique, incendie ou opération anormale. Ne pas désassembler, réparer ou modifier.

**Refer to the Operation Manual for other notes.**

## Precautions Related to Synthetic (Natural) Leather

### Clothing dye adhering

The color of clothing or belts can be transferred to the synthetic leather of this chair by means of contact. If color adheres to the leather, wipe off the stain as soon as possible before it soaks in by using a soft cloth that has been dabbed with a neutral detergent diluted with water to approximately one tenth, wipe it with a damp cloth and thoroughly wipe it dry.

Precautions regarding deformation and color transfer due to contact

### Precautions regarding deformation and color transfer due to contact

- Contact with other plastic parts, painted items, solvents, adhesive tape and similar items can result in changes in surface luster, cracking, deformation and peeling.
- Contact with newspaper or other printed items can result in color transfer.
- Contact with printed clothing such as t-shirts, jeans and similar items can result in color transfer such as by dye adhering to the leather.
- Adhering benzene, nail polish remover, alcohol, oil and similar substances can result in discoloration, surface dissolution, changes in luster, hardening or softening and peeling.
- Use of bleach, or use of a sheet or other cloth for which bleach has been used can result in changes in luster and color.
- Placement of an iron, heater or other excessive heat source near the chair can result in deformation and discoloration.
- Use a curtain or similar item to block the chair from exposure to direct sunlight. Exposure to direct sunlight can result in surface deformation, shrinking, discoloration, faded colors and similar problems.
- Placement of a heavy item for an extended period can result in marks or wrinkles that do not disappear after removing the item.

## Accessories

- Operation manual (this manual)
- Rotating table (OS type)
- Installation manual
- Foot cushion (OS type)

# Part Names

## ■ Main Unit

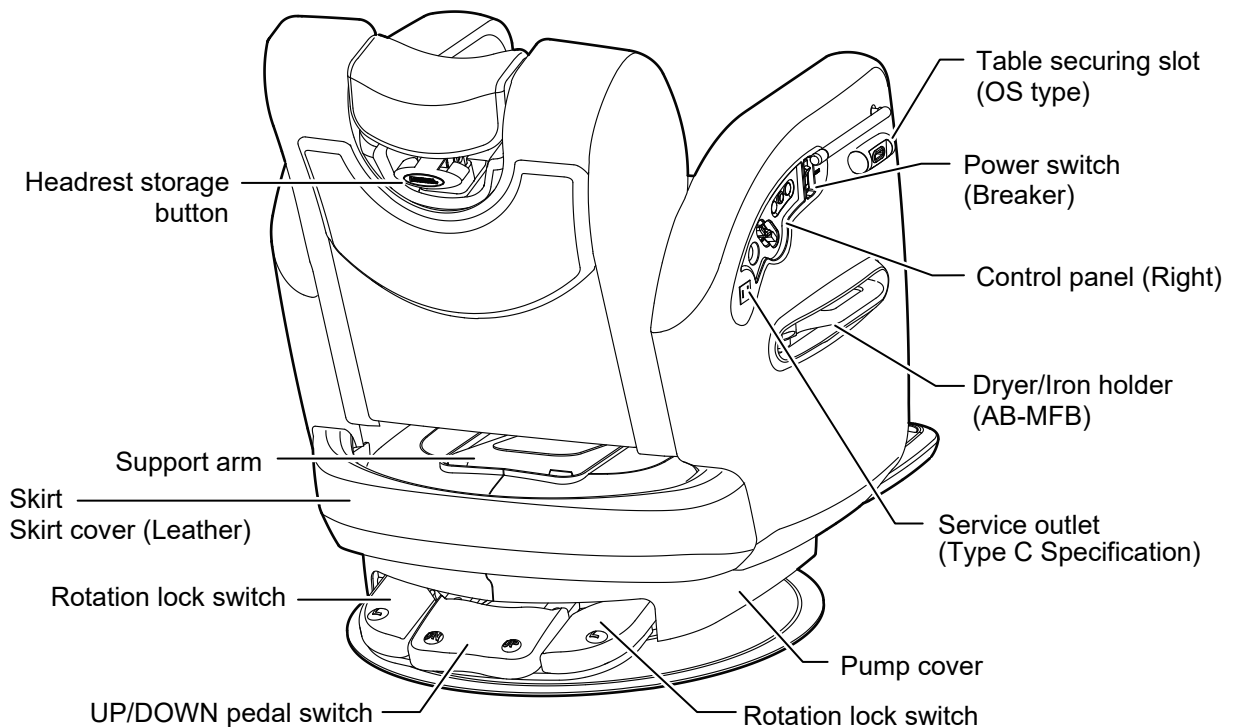
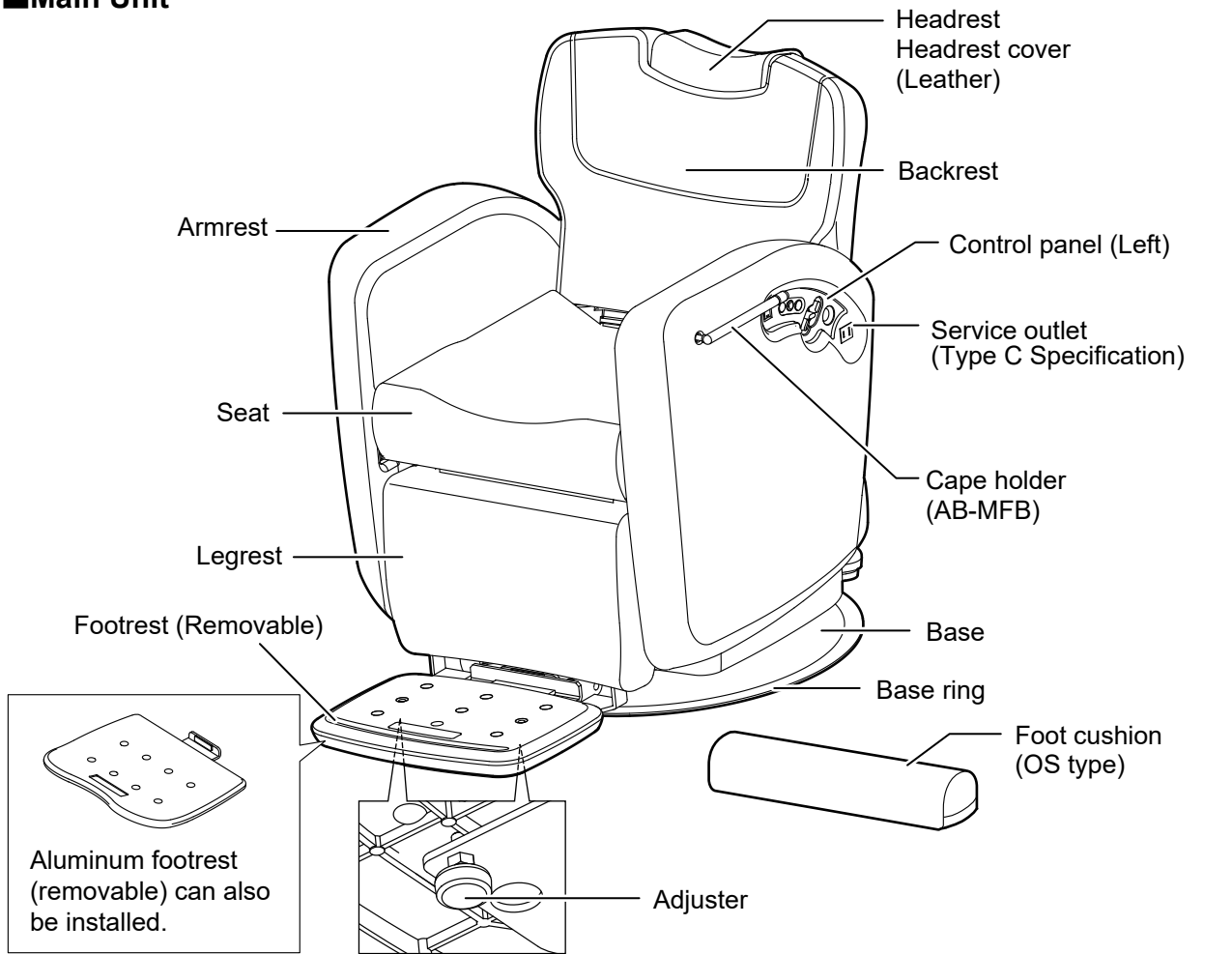

# Part Names

## Operating Unit

### Control Panel

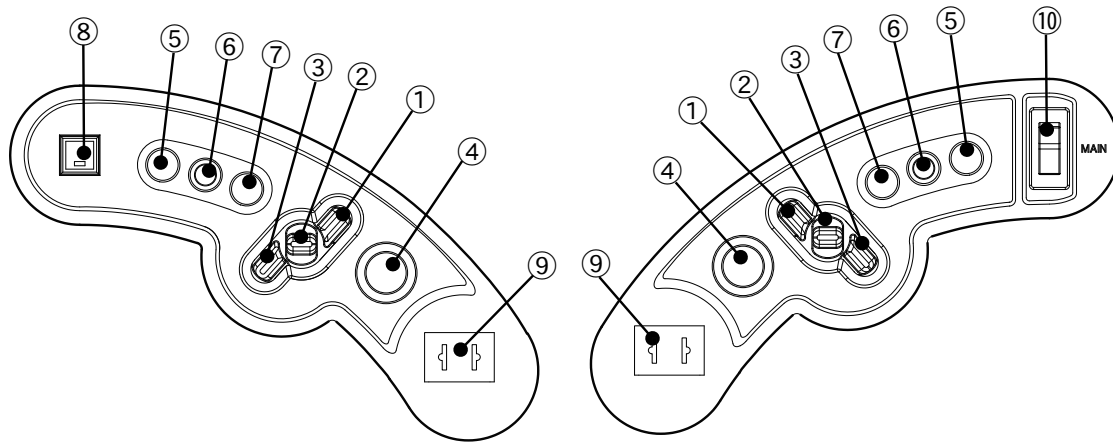

- ① Backrest switch
- ② UP/DOWN switch
- ③ Legrest switch
- ④ Auto-return switch (Auto-return LED)
- ⑤ Preset switch P1
- ⑥ Preset switch P2
- ⑦ Preset switch P3
- ⑧ Heater switch
- ⑨ Service outlet (Type C Specification)
- ⑩ Power switch (Breaker)

### Base Operation Section

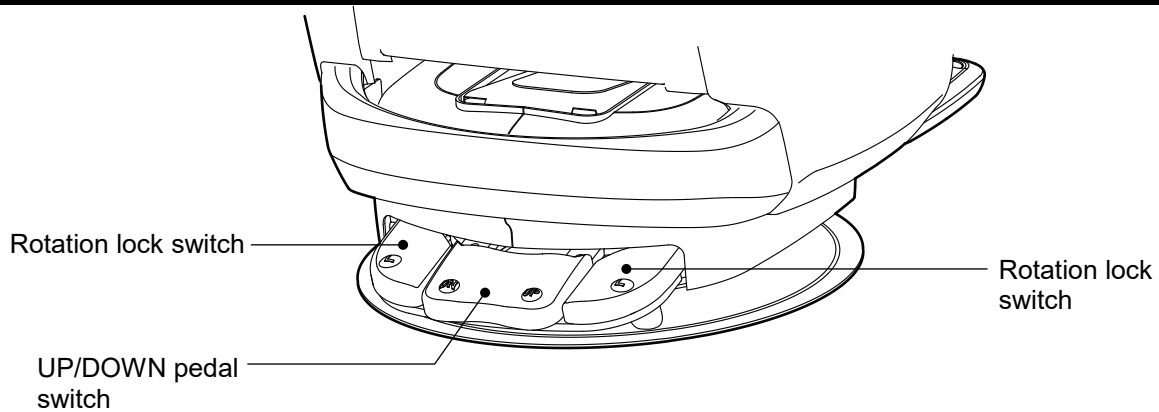

## Type Structure Overview AB-MF(1)(2)

(1)	S (For Ladies')		B (For Men's)		
	Standard (ST)	One-stop (OS)	Standard		One-stop (OS)
(ST)			(SB)		
Legrest-footrest linked type	○	○	○		○
Independent legrest type				○	
Cape holder			○	○	○
Dryer/Iron holder			○	○	○
Yume Swing position setting		○			○
Rotating table (table securing slot)		○			○
Accumulator (shockless)		○			○
Foot cushion		○			○

# Preparation

## ■ Power Supply

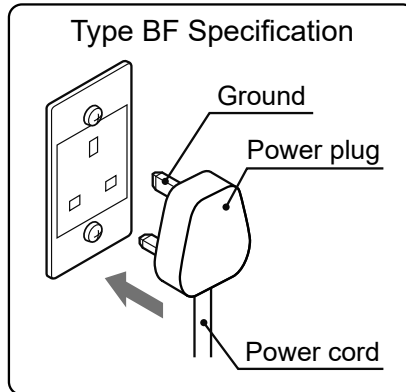
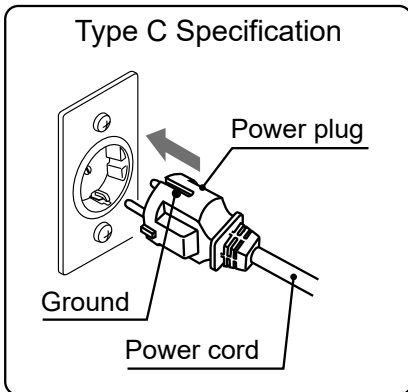

### 1. Insert the power plug into the outlet.



### WARNING

- Use an unshared outlet that has an attached ground terminal and matches the rated voltage and current \*of this product. Using the same outlet together with the power plug of other devices can result in abnormal heat generation and possible fire.  
\* 230V AC (12 A or more).
- Be sure to fully insert the power plug into the outlet until reaching the base of the plug.
- Do not pull the cord to remove the power plug from the outlet. Hold by the power plug at the end of the cord when removing.
- Do not touch the power plug, outlet or power switch with wet hands.
- Do not connect the earth (ground) to the following objects.  
Water pipes, Gas pipes, Lightning rods and telephone dedicated grounding wire
- Securely connect to ground. Consult an electrician for grounding procedures.
- Turn off the power switch and remove the power plug from the outlet when the chair is not to be used for a long period of time, such as at the end of work or during holidays.

### 2. Turn on the power.

The power switch is located on the control panel (right).  
Press the side with the  marking to turn the power on.  
Press the side with the  marking to turn the power off.  
When power is turned on, the auto-return LED blinks slowly.

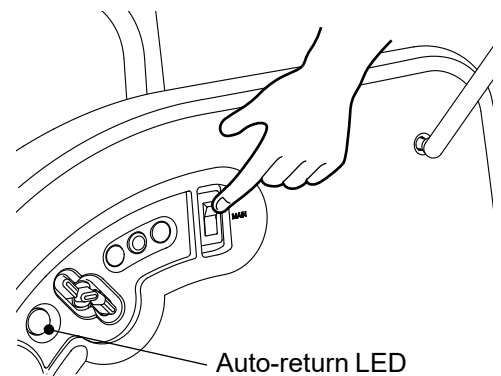
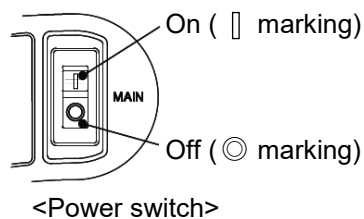

⇒ When the power is turned on, chair rotation is locked automatically.

 CAUTION Operate the power switch by using your hand.

# Use Procedures

## (1) Guiding Customers

### 1. Rotate the chair so that the customer can be easily seated on the chair.

#### 1 Step on the rotation lock switch.

Step on the rotation lock switch to release the lock and enable rotation of the chair.

(Operation is the same on either side.)

Chair rotation locking is performed by use of hydraulics.

The rotation lock repeatedly alternates between locked and released each time that the rotation lock switch is stepped on.

\* Cannot be operated when the power is turned off.

When the power is turned on, chair rotation is locked automatically. (The motor pump operates for approximately one second when rotation is locked.)

#### 2 Rotating the chair

Hold the backrest or armrests when rotating the chair.

You can rotate the chair a full 360°.

#### 3 Fixing the chair in a work position

Stop the chair at the desired work position and press the rotation lock switch in the base operation section. The chair is locked and prevented from rotating.

Turn on the power switch.

If the power is turned off, chair rotation is locked automatically when the power is turned on.

Press the desired switches.

If any of the switches of the base operation section or control panel (excluding the heater switch) is pressed, chair rotation is locked automatically.

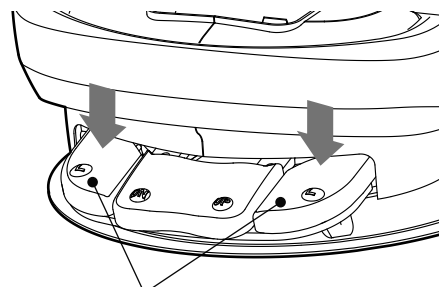

Rotation lock switch

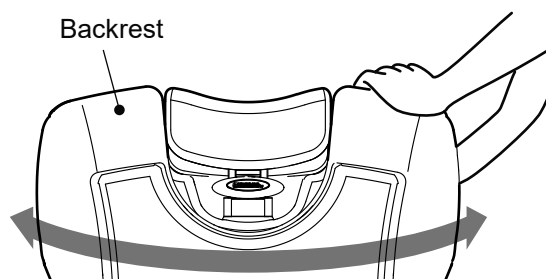

Backrest

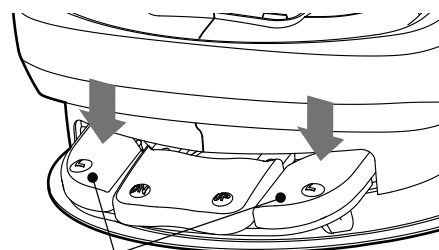

Rotation lock switch

<Base Operation Panel>

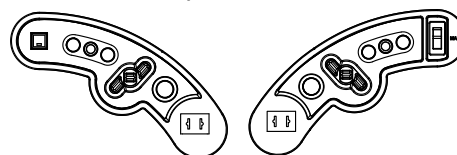

<Control Panel>

### WARNING

- Make sure that no persons or objects are nearby before slowly rotating the chair.
- When the backrest is fully reclined, rotate it with attention to the position in which the customer is lying and the posture of his/her body and limbs.
- Always lock the chair base after rotating the chair.



# Use Procedures

## 2. Using the cape holder (AB-MFB)

Using the cape holder:

- Provides space between the customer and the cutting cape to provide good ventilation.
- Makes it easy to clean up the cut off hair.

### 1 Rotate the pulled-out cape holder forward.

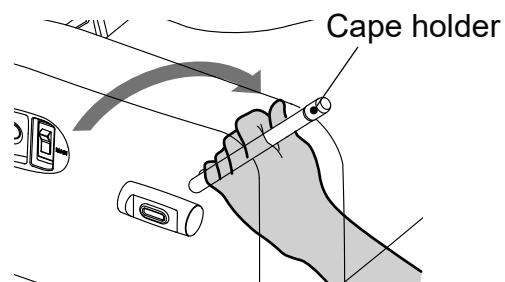

### 2 Pull out the tip of the cape holder and pinch the cutting cape.

(1) Pull from over the cutting cape.

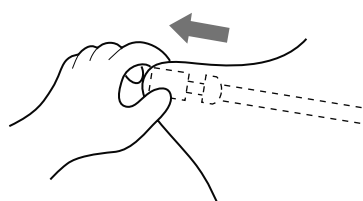

(2) Pinch the cape and release it.

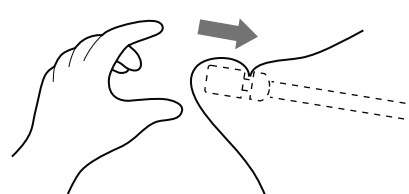

### 3 Rotate the cape holder rearward to store it.

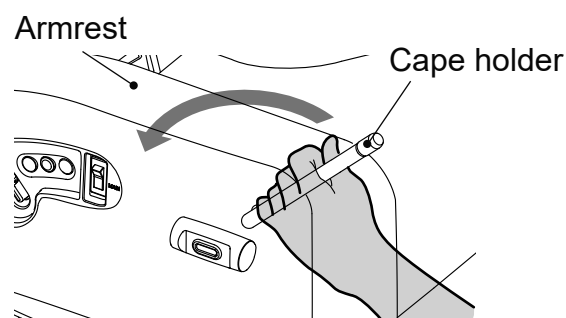

When using or storing the cape holder, hold and rotate it until it reaches its final position.

## CAUTION

- Be sure to store the cape holder when it is not used.
- When storing the cape holder, be careful not to get your or the user's fingers caught between the armrest and the cape holder.
- Use of the cape holder beyond its load capacity 10N(1kgf) may result in damage or injury, etc.

# Use Procedures

## (2) Raising/Lowering the Chair

### 1 Raising the chair

To raise the chair, step on the right side of the UP/DOWN pedal switch on the base operation section or press the UP/DOWN switch of the control panel (right or left) upwards. The chair operates while the stepping on (pressing) the switch.

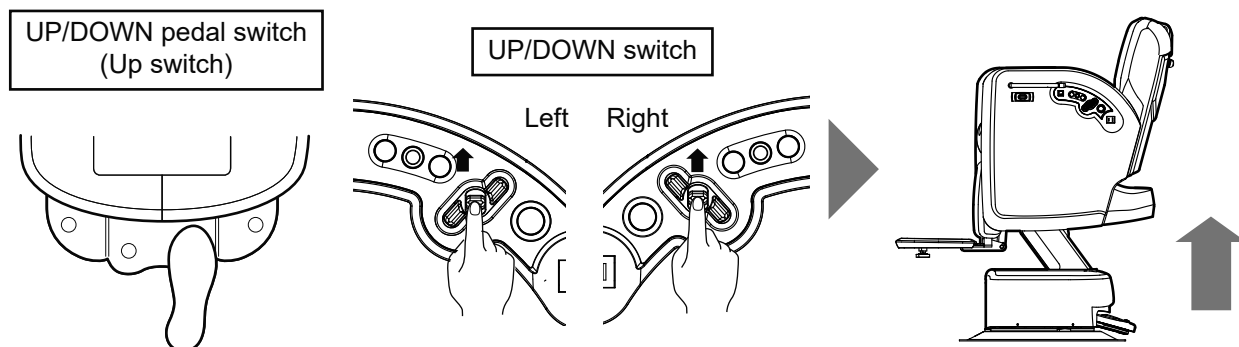

⇒ If any switch except for the heater switch is pressed while the chair rotation lock is released, chair rotation is locked automatically.

The body of this product moves backward as it moves up. Make sure that there are no obstacles in the front and back before operating the chair.

### 2 Lowering the chair

To lower the chair, step on the left side of the UP/DOWN pedal switch on the base operation section or press the UP/DOWN switch of the control panel (right or left) downwards. The chair operates while the stepping on (pressing) the switch.

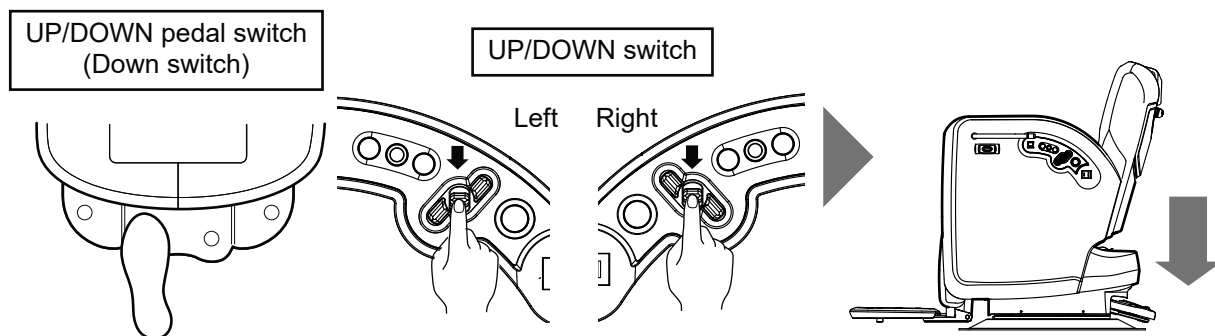

⇒ If any switch except for the heater switch is pressed while the chair rotation lock is released, chair rotation is locked automatically.

### **WARNING**

When raising or lowering the chair, make sure that there are no person, hands, feet, or objects nearby before operating the chair. Especially when lowering the chair, be careful not to get your foot caught under the footrest.

# Use Procedures

## (3) Reclining and Raising the Backrest

### 1. If using the lift-up headrest

#### 1 Lift up the headrest operation lever and pull up the headrest.

Secure the headrest at the desired position so that you can use it at that position. A stopper is provided so that the headrest cannot be completely pulled out. It can be pulled out up to a maximum of 28 cm. If the headrest is excessively pulled out, return it while pressing the headrest operation button.

Do not press the headrest operation button when pulling up the headrest from its stored position. It makes the headrest fall forward when the headrest is pulled up and may interfere with the backrest, causing damage to the leather of the backrest.

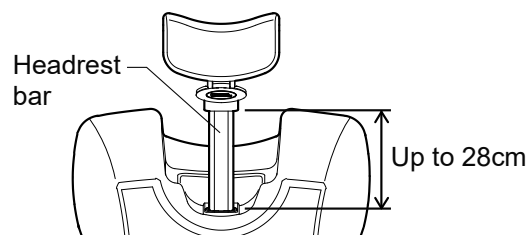
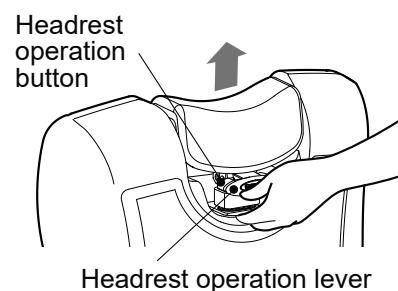

#### 2 While pressing the headrest operation button, tip the headrest forward.

Tip the headrest forward to fit it against the customer's head so that the customer will be more comfortable even if used for an extended period.

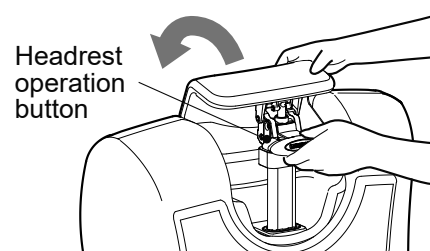

#### 3 Store the headrest when finished using it.

While holding the headrest operation lever and pressing the headrest operation button, return the headrest to its original position and lower it.

Move the headrest back to the original angle, and then lower the headrest. If the headrest is lowered being tilted forward, it may interfere with the backrest, causing damage to the leather of the backrest.

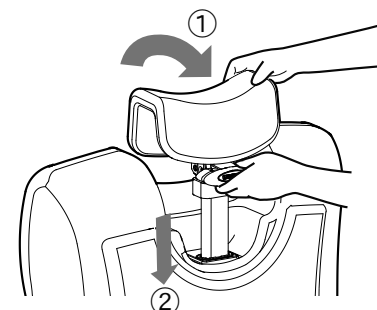

- Do not apply excessive load or shock to the headrest. Doing so can result in damage.
- Be sure to always store the headrest when performing a back shampooing. Otherwise, the shampoo bowl will interfere with the headrest possibly resulting in breakage.

### CAUTION

- Wipe off all water and chemicals immediately if any gets on the headrest bar. Failure to do so can prevent the headrest from being securely fixed because of corrosion or degradation of friction force due to rust.
- Be careful when operating the headrest that fingers and other body parts are not pinched between the area around the operating lever or in between the headrest and backrest.
- Be careful not to catch customer's hair or clothing when storing the headrest.

# Use Procedures

## 2. Reclining the backrest

Push the backrest switch of the control panel (right or left) in the direction of the arrow to recline the backrest. The chair operates while the switch is pressed.

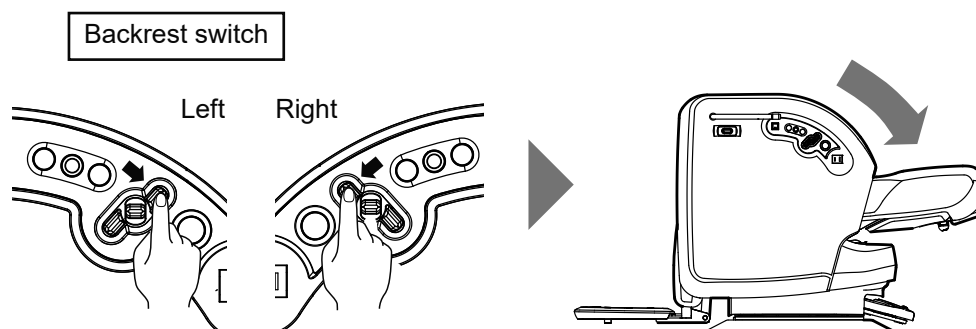

⇒ If any switch except for the heater switch is pressed while the chair rotation lock is released, chair rotation is locked automatically.

### **WARNING**

- When raising/reclining the backrest, make sure that there are no hand or fingers of the customer between the backrest and the body/seat.
- Carefully recline the backrest so that the headrest or backrest will not contact any shampoo bowl or nearby equipment.
- When the backrest is laid down, the body lowers in conjunction with it. Be careful not to pinch your body or objects under the body or between the body and the pump cover.

## 3. Raising the legrest

Push the legrest switch of the control panel (right or left) in the direction of the arrow to raise the legrest. The chair operates while the switch is pressed. The legrest of legrest-footrest linked type rises together with the footrest.

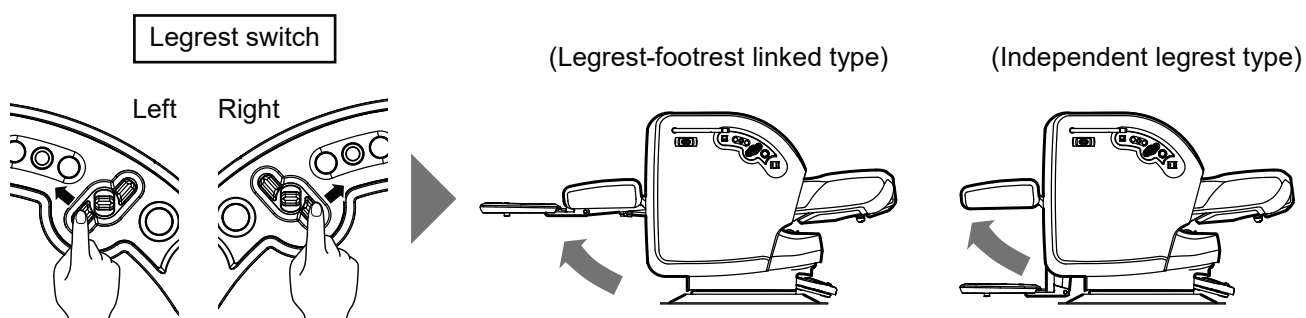

⇒ If any switch except for the heater switch is pressed while the chair rotation lock is released, chair rotation is locked automatically.

### **WARNING**

When raising the legrest, make sure that customer's toes or the footrest does not come in contact with peripheral equipment.

# Use Procedures

## 4. Lowering the legrest

Push the legrest switch of the control panel (right or left) in the direction of the arrow to lower the legrest. The chair operates while the switch is pressed. The legrest of legrest-footrest linked type lowers together with the footrest.

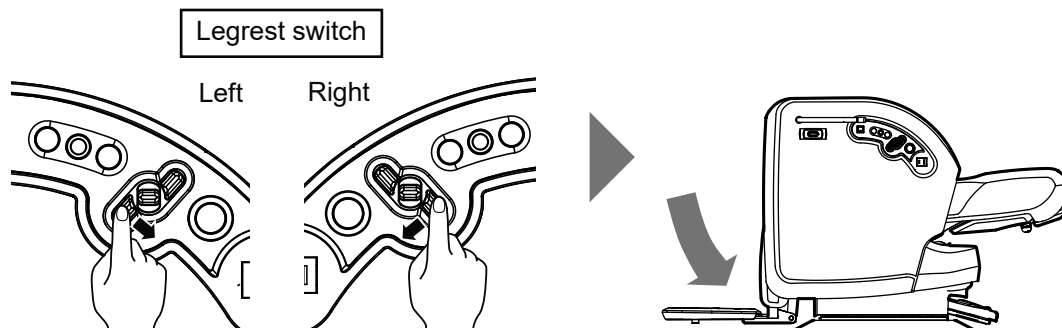

⇒ If any switch except for the heater switch is pressed while the chair rotation lock is released, chair rotation is locked automatically.



### WARNING

When lowering the legrest, make sure that there is no person or object under the legrest or footrest.

## 5. Raising the backrest

Push the backrest switch of the control panel (right or left) in the direction of the arrow to raise the backrest. The chair operates while the switch is pressed.

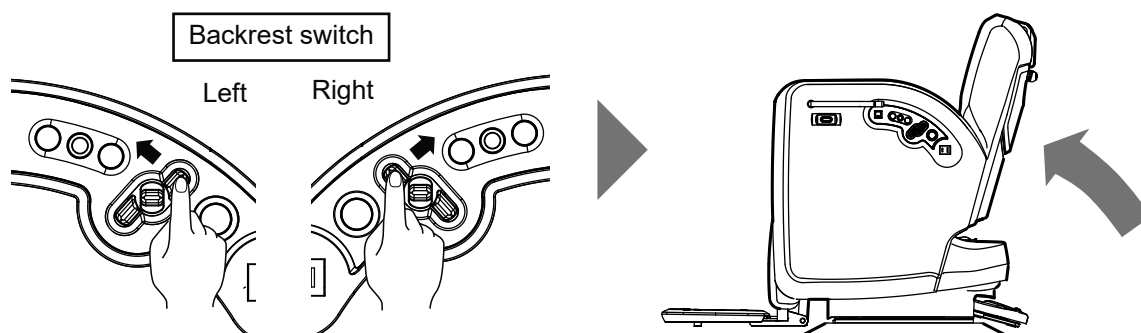

⇒ If any switch except for the heater switch is pressed while the chair rotation lock is released, chair rotation is locked automatically.

Use the preset function to move the chair to the predetermined position.  
Refer to "(4) Using Preset Function".



### WARNING

When raising the backrest, make sure that there are no hand or fingers of the customer between the backrest and the body/seat.

# Use Procedures

## (4) Using Preset Function

### 1. Preset Function

The preset function allows you to press a switch once to move the chair to the previously set work position. You can set up to three optional positions of this chair. The auto-return LED blinks rapidly during preset operation.

- 1 Pull the headrest out to the desired position previously when you need to use it.
- 2 Press a preset switch on the control panel (right or left) once.  
The chair moves to the previously set position.

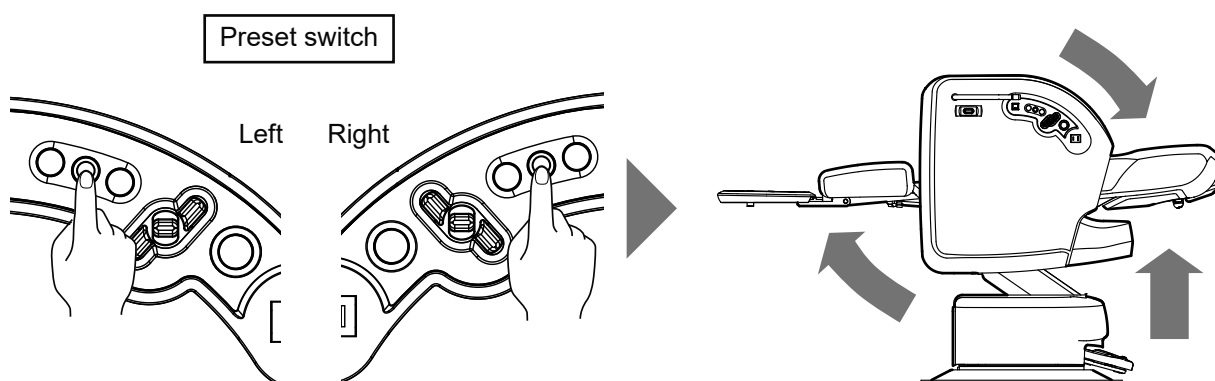

⇒ If any switch except for the heater switch is pressed while the chair rotation lock is released, chair rotation is locked automatically.

### **⚠ WARNING**

- When using the preset function or Auto-return function, check that there are no people's body, hand, foot, or objects in the vicinity, then operate the chair.
- When an elderly customer or a small child is sitting down, the operation may be unexpectedly burdensome due to the posture change caused by the auto operation. Stop the operation immediately if you feel any abnormal changes.

### <Changing Settings of the Preset Function>

Although the operation settings positions of the preset switches are previously set when shipped from the factory, you can change to the operation positions to match your customers. Perform the following procedures to change the operation settings positions.

- (1) Move the chair to the position you want to use.
- (2) Turn off the power switch, and then press and hold down a preset switch (P1, P2, or P3) while you turn on the power switch.
- (3) Continue to press and hold the preset switch for approximately three seconds until you hear an electronic beep indicating that the position is set.
- (4) Setting is completed when the electronic beep is emitted. Return the chair to its original position by using the auto-return switch, and use the preset switch for which you have changed the setting to make sure that the chair moves to the position you have set.

# Use Procedures

## Using Preset Switch P3 (Last and facial positions)

Although the preset function of preset switch P3 can be used to function in the same normal manner as preset switches P1 and P2, you can change the setting of P3 to change it to a useful function that matches the desired customer use (last and facial positions).

\* As the setting when purchased is "Normal Preset Function", perform these procedures only if you want to change the settings. Be careful to perform the procedures correctly because you might mistakenly change other settings, resulting in faulty operation.

### ■ Last Position Function

**You can use this function after you have finished cutting hair and moved the chair to the shampoo position by using preset switch P3. Press preset switch P3 again to return the chair to the position you were just using for the cut. This function is useful because you do not need to readjust the chair by using this setting, making for smooth and easy cutting.**

By setting the last position function for preset switch P3, the chair moves to the set position when you press preset switch P3. After the procedures, press preset switch P3 to return the chair to the position of when you previously pressed preset switch P3.

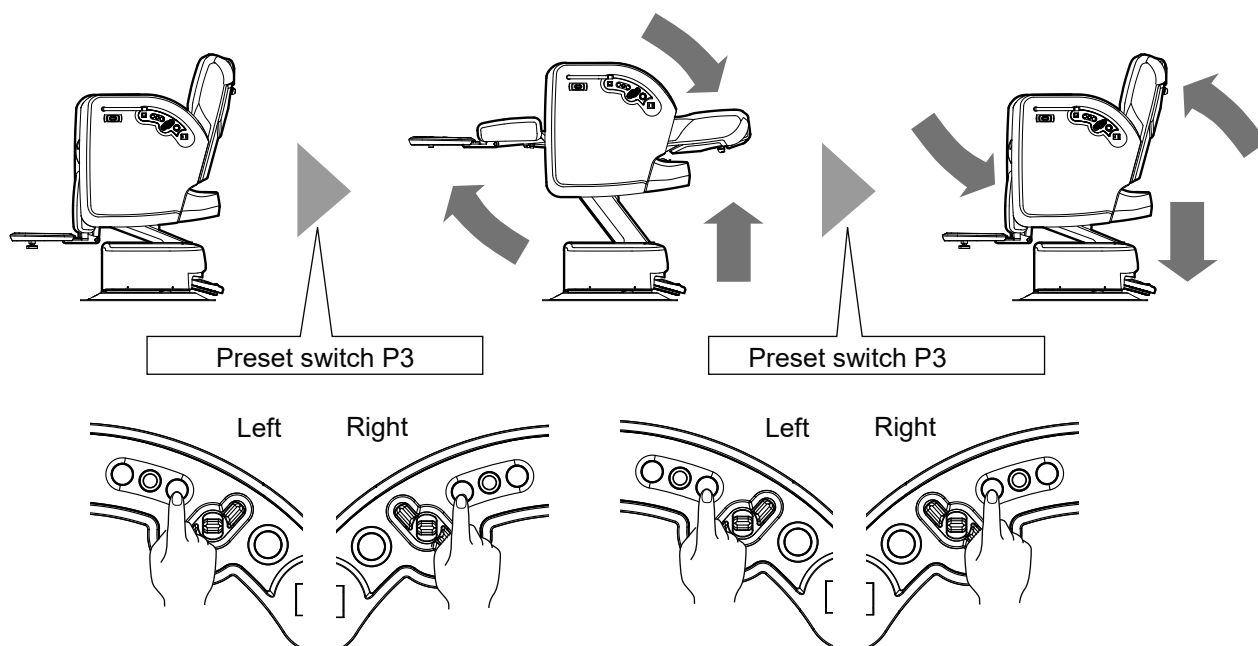

# Use Procedures

## ■ Facial Position Function

This function is useful as it allows you to recline and raise the chair without changing the height of the customer. For example, you can use this function if you want to reduce the work time or repeatedly check in the front mirror in the case of a facial service.

By setting the facial position function for preset switch P3, only the back and legrest move to the set position (height does not change) when you press preset switch P3.

After the procedures, press preset switch P3 to return the back and legrest to the position of when you previously pressed preset switch P3. (Height does not change.)

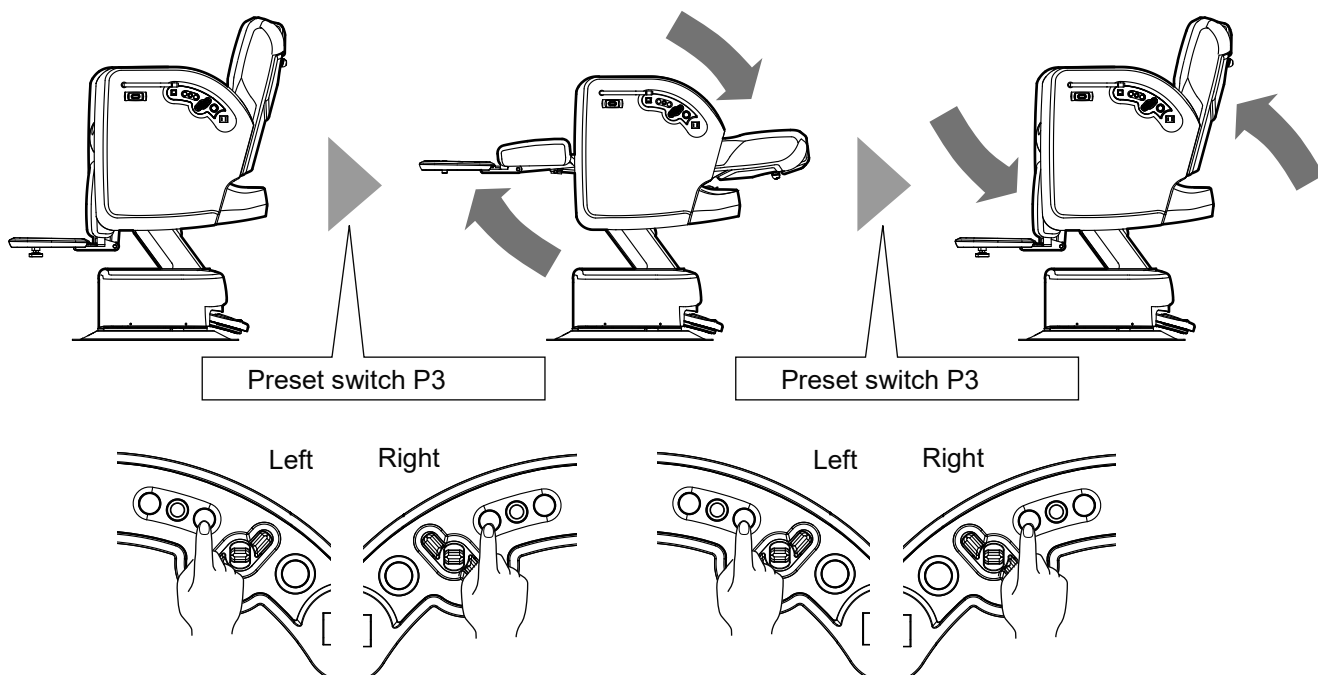

## [Setting Procedures]

- (1) Turn off the power switch, and step on the rotation lock switch, and press and hold the backrest up switch while turning on the power switch.
- (2) Continue to step on the rotation lock switch, and press and hold the backrest raise switch for approximately three seconds until you hear an electronic beep. Check which function is set by checking the tone of the beep. The setting changes in the following order: A => B => C => A  
Perform procedures (1) and (2) repeatedly until reaching the desired function.

### [Beep Tone]

A: Normal preset function...Continuous high-pitched beep

B: Last position function...Beep is repeated twice.

C: Facial position function...Beep is repeated three times.

- (3) If setting to the last or facial position function, use preset switch P3 to first perform the previously described "Changing Settings of the Preset Function".

\* The settings are saved even if the power is turned off so that the function will operate in the same manner as when the power was previously turned off and turned on.



# Use Procedures

## 2. Auto-Return Function

Press the auto-return switch on the control panel (right or left) once. The chair height, backrest angle and legrest position return to their initial position (position for getting in/out of chair). The auto-return LED blinks rapidly during auto-return operation.

(An electronic "pough" sound is emitted to notify you that operation is starting.)

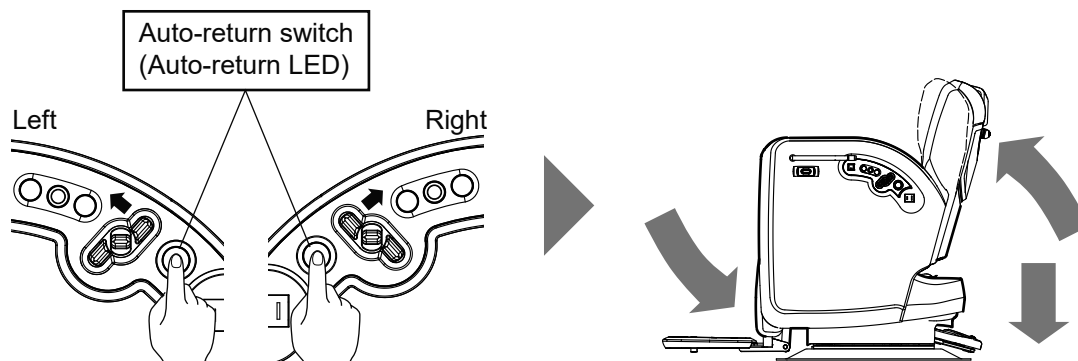

⇒ If any switch except for the heater switch is pressed while the chair rotation lock is released, chair rotation is locked automatically.

Although the switches of the controlpanels are positioned slightly inset to prevent body parts from touching them, keep body parts away from the operation panels as much as possible. If a body part touches a switch, it will cause a faulty operation

### **WARNING**

- When using the preset function or Auto-return function, check that there are no people's body, hand, foot, or objects in the vicinity, then operate the chair.
- When an elderly customer or a small child is sitting down, the operation may be unexpectedly burdensome due to the posture change caused by the auto operation. Stop the operation immediately if you feel any abnormal changes.

## 3. Cancel Function

Press any switch other than the heater switch if you want to stop chair operation midway when using the preset or auto-return switches. The cancel function operates to stop chair operation. (An electronic beep is emitted when auto-return operation is canceled.)

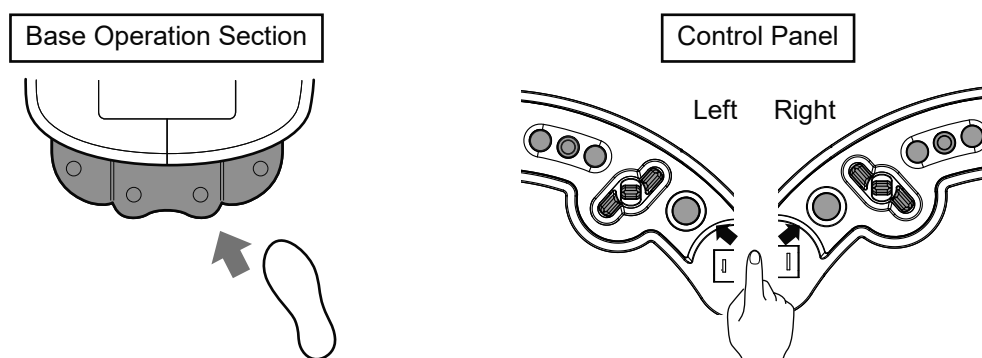

You can use the switches on both the left and right controlpanels to stop operation.

 Press any of the switches shaded in gray to stop operation.

# Use Procedures

## (5) Removable Footrest

You can remove the footrest anytime it might interfere such as when sitting a wheelchair customer in the chair or using a foot spa machine. If using the independent legrest type (AB-MFBSB), raise the legrest and make the guide visible before performing work.

### (Legrest-footrest linked type)

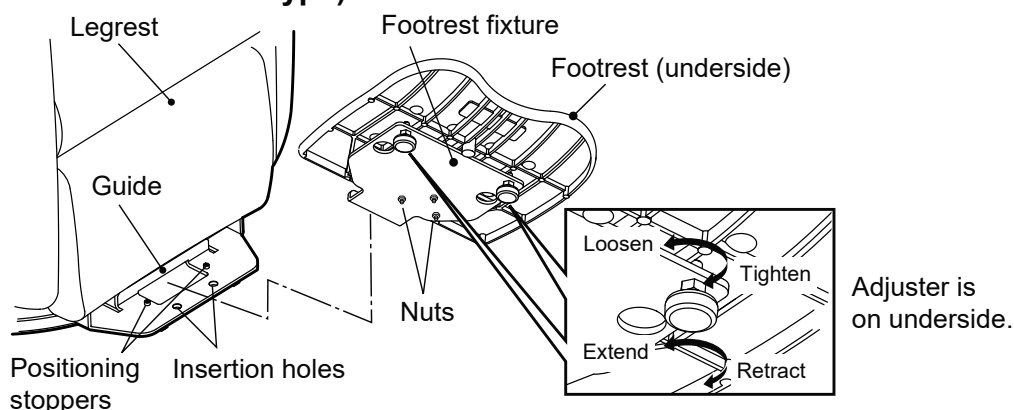

### (Independent legrest type)

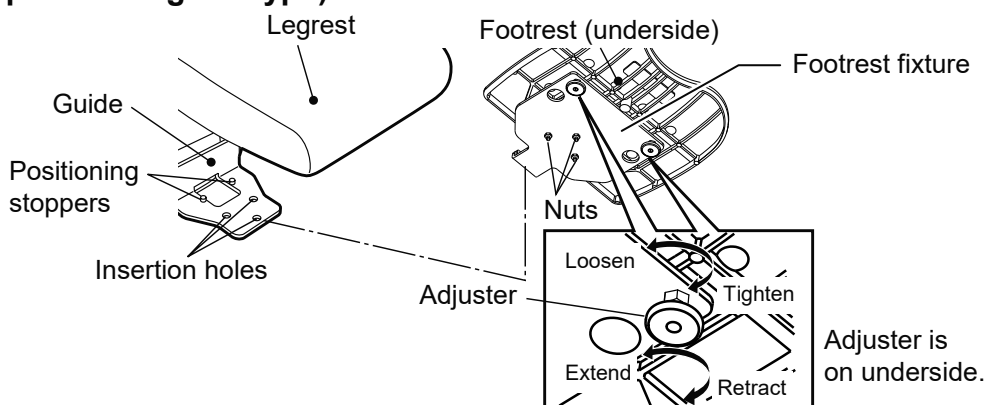

#### 1 Footrest Removal

Remove the footrest fixture held by the guide and remove the footrest.

#### 2 Footrest Installation

Holding the footrest fixture against the positioning stoppers, attach the footrest fixture to the guide, and securely insert the nuts on the underside of the footrest into the two (three for independent legrest type) insertion holes.

- Be careful of operating the chair when using a foot bath and make sure that the chair does not interfere with the foot bath.
- Immediately wipe off any water, cosmetic agent or other liquid of the foot bath if it gets on the chair. Not wiping it off can result in rust or other damage.

### ⚠ WARNING

- After installing the footrest, make sure that the footrest bracket is firmly hooked to the footrest mount and that the footrest is kept level. Failure to do so may result in injury.
- Be careful when lifting and carrying the footrest, and of where you place it because the footrest is heavy. Dropping the footrest could result in injury or damage the floor.

### ⚠ CAUTION

When adjusting the height of the adjuster, make sure that the adjuster does not rub on the floor or catch the power cord when the chair is rotated. On the contrary, adjust the height so that the product does not fall over even if the customer gets on the footrest at exit/entry position.

# Use Procedures

## (6) Heater

This chair is equipped with a legrest heater.

### 1 Operating the heater

Press the heater switch ("HEATER") on the controlpanel (chair left side) to operate the heater (Heater light turns on.)

Left  
heater switch

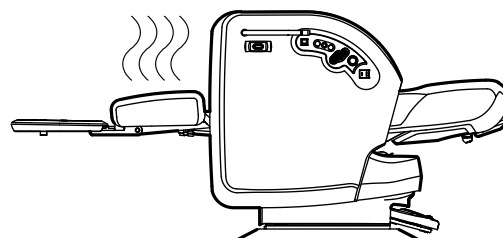

Heat will escape and the effective temperature reduced if the customer's calves do not contact the legrest. Use the heater with the legrest raised.

### 2 Stopping the heater

Press the heater switch again to stop heater operation. (Heater light turns off.)

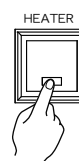

## WARNING

- Be sure to turn off the heater switch when not necessary. Using the heater for an extended period causes the temperature to increase, possibly resulting in burns or fire.
- Do not use the heater for a long time. Doing so may cause low-temperature burns. Should red spots or blister occur, immediately take the diagnosis of a medical specialist.
- If you notice abnormal heat when using the heater, turn off the power switch, unplug the equipment, and contact your authorized Takara Belmont dealer.

## (7) Accumulator (OS Type)

This chair is equipped with an accumulator that reduces vibration when operating and stopping the chair. The accumulator absorbs loads applied to the chair to provide shock-free performance. Accordingly, the following conditions might be observed.

- The stopping position of the chair might vary due to slowly stopping the chair in order to absorb shocks.
- The chair might seem to slightly bounce due to load changes when getting in or out of the chair, or during massage.
- The chair might rise slightly when a customer gets out of the chair. (Due to the load applied to the customer being absorbed when a customer sits, causing the chair to sink.)

# Use Procedures

## (8) Yume Swing Bowl Positioning (OS Type)

This chair is equipped with a "Yume Swing Position Setting" in the chair base that detects position in order to be able to properly align the positions of the Yume Swing bowl and chair rotation.

- 1 Release the rotation lock and rotate the chair.
- 2 Rotation becomes slightly heavy as you slowly rotate the chair until it is near the Yume Swing bowl position and you feel a slapping click.
- 3 After the chair secured at the position in 2, you can press a previously set preset switch to align the chair and Yume Swing bowl at the proper position.

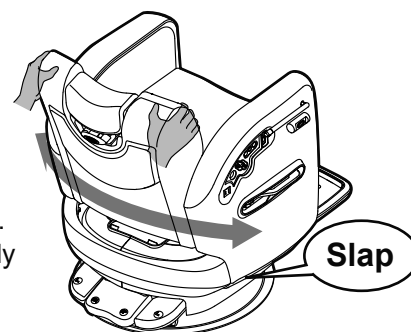

- Lock the chair at the Yume Swing setting position so that the Yume Swing position setting and the bowl are aligned at the proper position, and check that the chair and bowl are properly aligned.
- Reposition the Yume Swing setting position to the proper position after moving the chair for cleaning or similar reason because the position might become misaligned due to such movement.
- The Yume Swing position setting has a simple lock for position detection. Always be sure to fully lock it by using the rotation lock switch after aligning the position because the lock can be released with only slight force.

### • Yume Swing Position

The Yume Swing position consists of the two positions shown below. Use these in alignment with the bowl position.

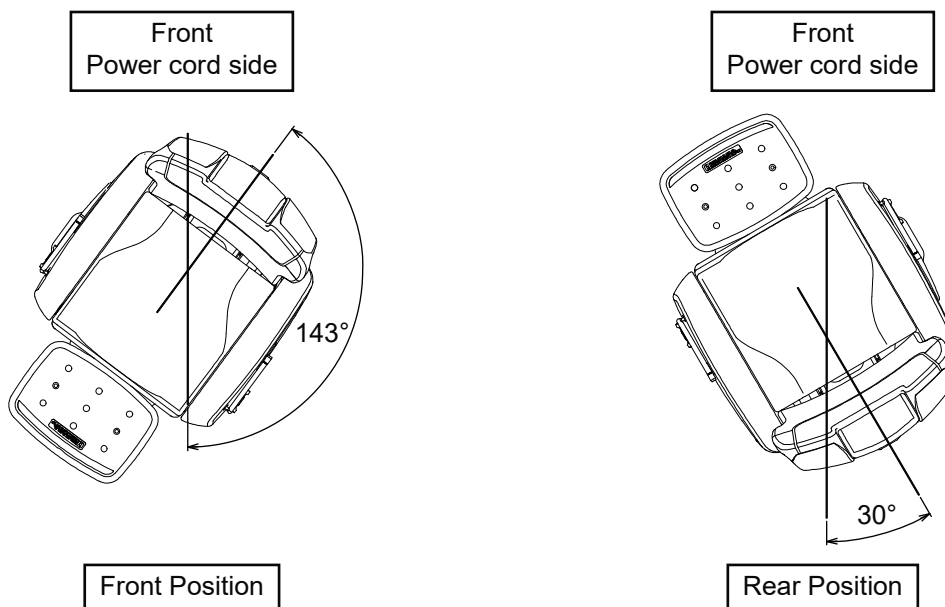

# Use Procedures

## (9) Dryer/Iron Holder (AB-MFB)

Pull out the dryer/iron holder at the center of the body on the right side of the chair.  
You can use this as a stand for a hand dryer or iron while working.

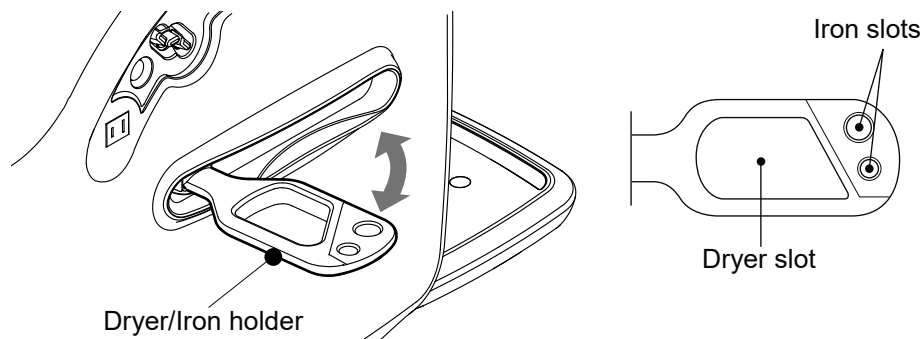

- Store the dryer/iron holder when not in use.
- Do not rotate the dryer/iron holder with a hand dryer or iron still inserted in the slot.  
Doing so may damage the product or peripheral equipment, or deform/deteriorate it with heat.



### CAUTION

- Be careful not to let the operator's feet come in contact with the dryer/iron holder.
- Use of the dryer/iron holder beyond its load capacity 50N(5kgf) may result in damage or injury.

# Use Procedures

## (10) Service Outlets (Type C Specification)

This chair is equipped with service outlets on the right and left control panels.

Total (right and left sides) current available for use is 12 A or less when not operating the chair and 9 A or less when operating the chair. The power switch (right control panel) is turned off if the current available for use is exceeded. If this occurs, stop using the connected device(s), and turn on the power switch again.

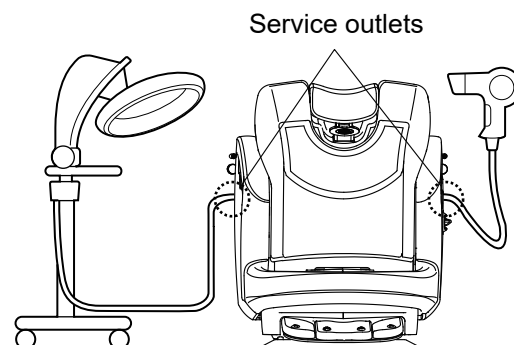

### **WARNING**

- Be sure to fully insert the power plug of the device being used into the outlet until reaching the base of the plug. Failure to fully insert the plug or similar loose connection can result in a short circuit or heat generation that causes a fire.
- If the connection becomes loose, immediately stop using the equipment attached to the service outlet and unplug the equipment from the service outlet. Contact your authorized Takara Belmont dealer as soon as possible for inspection or replacement parts.
- Remove the power plug of a device from the outlet when not using it.
- If any water gets on a service outlet, immediately turn off the chair power switch, remove the plug, and wipe away the water. Additionally, if a substantial amount of water gets inside a service outlet, immediately remove the plug and contact your authorized Takara Belmont dealer.
- Do not touch a service outlet with a wet hand.
- If needed, use a suitable conversion adapter as 12A or higher.
- When a conversion adapter is used, make sure that it is firmly plugged into the service outlet. Loose connection can make the adapter heated up and lead to fire.

# Use Procedures

## (11) Rotating Table (OS Type)

- 1 Insert the rotating table into the table securing slot on the side of the body until it is fully and securely inserted.
- 2 As the rotating table can rotate a full 360°, you can set it to the proper position for the service you want to provide, such as using it as a temporary stand for an ashtray, drink, book and similar items, or for use during nail work, hand care and similar procedures.
- 3 To remove the rotating table, hold the table stay and pull it out horizontally while holding the table by hand. Use both hands when inserting or removing the rotating table as it weighs 3kg.

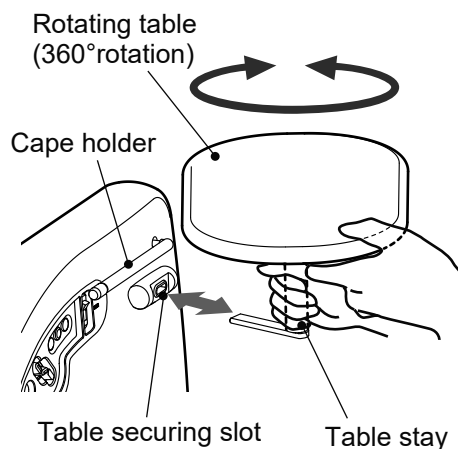

- Do not lift or move the table up or down when removing the rotating table. It may cause deformation or damage of the table securing slot or table part.
- Do not operate the chair with objects placed on the rotating table. Otherwise, objects on the table may fall or spill.
- Do not place objects on the rotating table that weigh 5 kg or more, or items that hang over or extend beyond the table surface. Doing so can result in damage to or deformation of the main body or table.
- Do not insert or remove the rotating table with items placed on the table. Doing so can result in such items falling off or in spilling of liquids.
- Do not use the cape holder when using the rotating table. Doing so can result in damage to or deformation of the cape holder or table.

### CAUTION

- Check that the table is securely inserted into the table securing slot before using the table. Failure to fully insert the table can result in the table falling off, causing injury and damage.
- Always be sure to pull out and carry the rotating table with both hands as it is heavy, and store it in a stable location. Accidentally dropping the table could result in serious injury.
- Be careful when using the rotating table that the customer's fingers or hands do not interfere with the table when raising the backrest.
- Immediately wipe off any chemical solutions that spill on the table.
- Be careful when rotating the rotating table that the customer's fingers or hands do not interfere with the table.
- Be careful that nearby devices such as the bowl do not interfere with the table when rotating or operating the chair while using the table.

# Use Procedures

## (12) Foot Cushion (OS Type)

This chair has a foot cushion that can be placed on the footrest on which the customer's legs can rest in order for the customer to recline with comfort.

Use it for customers whose height is such that their heels extend beyond the legrest.

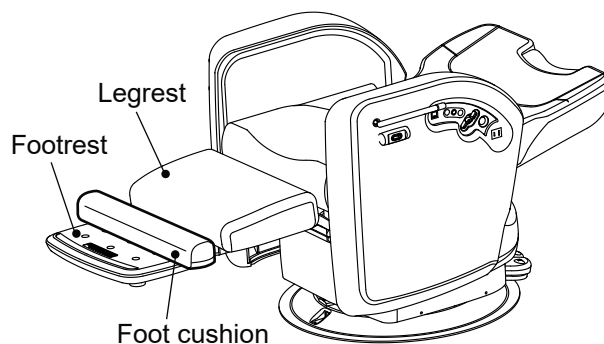

Always be sure to remove the foot cushion before returning the legrest to its original position. Returning the legrest with the cushion still located on the legrest can result in the cushion being pinched between the legrest and footrest.



### **CAUTION**

Remove the foot cushion from the footrest when the customer gets in and out of the chair. Otherwise the customer may fall over causing injury.



# Cleaning Procedures

Clean this chair after use to maintain it in a clean state.  
Leaving dirt or grime on the chair can result in the formation of mold.

## **WARNING**

- Turn off the power switch and unplug the power plug before cleaning. Failure to do so can result in electric shock or fire. Unexpected activation of the product may cause injury.
- Do not sprinkle with water to clean it. Washing in such a manner can result in a malfunction or electric shock.

## **CAUTION**

The metal and mechanical parts of the chair have sharp edges. Be careful when cleaning the chair that your hands, fingers or other body parts are not injured.

## Cleaning of Each Part

### Leather Parts

Lightly wipe clean using a dry soft cloth.

If extremely dirty

### Plastic Parts

Wipe off any stain by using a soft cloth that has been dabbed with a neutral detergent diluted with water to approximately 10%, wipe it with a damp cloth and thoroughly wipe it dry.

### Control Panels

Wipe clean using a dry soft cloth.

### Metal Parts

Do not clean these parts with a wet cloth because they are readily affected by moisture and water. Wipe off all moisture immediately if any water gets on these parts. Water left on these parts will result in deterioration, rust, and malfunction of electronic parts.

- Do not use any of the following substances to clean the chair.  
Thinner, alcohol, nail polish remover, volatile chemicals (such as gasoline or kerosene), acid or alkaline solutions, chlorinated cleaners, disinfectants that are highly corrosive to metal, povidone iodine (iodine solution), sodium hypochlorite, waxes containing abrasive compounds, sponges containing abrasive compounds and similar substances.
- Do not use brushes, scouring brushes or similar items when cleaning the chair. Using them will damage the chair or result in the inability to clean off the dirt or grime.
- Do not clean leather parts using a cleaner or bleach containing organic solvent or abrasive compounds. Such substances can cause the leather surface to deteriorate or dull the luster.

Clean a chair that has not been used for an extended period before using again.  
After cleaning, be sure to always check that the chair operates properly.

## Spray-type Hairstyling Products (Especially hard types)

When using spray-type hairstyling products (especially hard types), check the entire chair to make sure that none of the product is adhering to the exterior surface of the chair (including leather parts). Immediately wipe off any hairstyling product that is adhering to the chair. Allowing such hairstyling product to remain results in it becoming firmly adhered, leaving a feeling of roughness. Be especially careful of flat surfaces (such as the plastic covers) as this roughness is considerably noticeable on flat surfaces.

### \* If hairstyling product has become firmly adhered:

Clean off any firmly adhered hair product by using ethanol. However, repeatedly cleaning off product adhering to plastic covers and leather parts by using ethanol can cause the surface to deteriorate, paint to peel, the luster to be lost, and cracking. To prevent this, immediately wiping off any adhering hairstyling product is the best method to prevent any problems.



# Daily Inspection

Perform the following inspection procedures in order to ensure that the chair can be used safely. If the chair does not operate normally, stop using the chair, turn off the power, unplug the power plug, and contact your authorized Takara Belmont dealer.



## WARNING

Be sure to always perform daily inspection according to the following instructions. Failure to do so may result in injury or damage to peripheral equipment or facilities.

### Daily Inspection Procedures

Inspection Items	Inspection Procedures	Recovery Procedures if there is a Problem
<input type="checkbox"/> Check that the chair operates normally.	<input type="checkbox"/> Check that a double beep with one to three pauses are not emitted intermittently after turning on the power switch.  <input type="checkbox"/> Check that, approximately five seconds after turning on the power switch, a double beep with five pauses are not emitted intermittently.  <input type="checkbox"/> Check that the chair moves normally to the preset positions by using the preset switches.  <input type="checkbox"/> Check that the chair moves normally to the initial position (position for getting in or out of the chair) by using the auto-return switch.  <input type="checkbox"/> Check that the chair raises and lowers by using the UP/DOWN switches and pedal switches.	<input type="checkbox"/> Turn off the power switch, and wait approximately five seconds before turning on the power switch again. If the alarm still sounds, the position detector might be faulty. Stop using the chair, turn off the power, unplug the power plug, and contact Takara Belmont or its distributors.  <input type="checkbox"/> Check that none of the operating switches are pressed. After checking that there is no object on top of the foot switch or other things, turn off the power switch, and wait approximately five seconds before turning on the power switch again. If the alarm still sounds, one of the operating switches might be faulty. Stop using the chair, turn off the power, unplug the power plug, and contact Takara Belmont or its distributors.  <input type="checkbox"/> Perform the procedures indicated in "1. Preset Function" of "(4) Using Preset Function" under "Use Procedures" (p. 22). If operation is still not normal, stop using the chair, turn off the power, unplug the power plug, and contact Takara Belmont or its distributors.  <input type="checkbox"/> Perform the procedures indicated in "2. Auto-Return Function" of "(4) Using Preset Function" under "Use Procedures" (p. 25). If operation is still not normal, it might not be possible to safely get in and out of the chair. Stop using the chair, turn off the power, unplug the power plug, and contact Takara Belmont or its distributors.  <input type="checkbox"/> Perform the procedures indicated in "(2) Raising/Lowering the Chair" under "Use Procedures" (p. 18). If operation is still not normal, it might not be possible to safely get in and out of the chair. Stop using the chair, turn off the power, unplug the power plug, and contact Takara Belmont or its distributors.

# Daily Inspection

Inspection Items	Inspection Procedures	Recovery Procedures if there is a Problem
<p><input type="checkbox"/> Check that the chair operates normally.</p> <p><input type="checkbox"/> Check that there are no abnormal noises emitted from the chair.</p> <p><input type="checkbox"/> Check that there are no abnormal odors emitted from the chair.</p> <p><input type="checkbox"/> Check that no oil is leaking.</p>	<p><input type="checkbox"/> Check that the chair backrest can be reclined and raised by using the backrest switch.</p> <p><input type="checkbox"/> Check that the chair legrest can be raised and lowered by using the legrest switch.</p> <p><input type="checkbox"/> Check that chair rotation can be locked and unlocked by using the rotation lock switch.</p> <p><input type="checkbox"/> Check that there is no wobbling or abnormal noise when operating the chair.</p> <p><input type="checkbox"/> Check that no abnormal odors or smoke is being emitted from the chair.</p> <p><input type="checkbox"/> Check that the chair stops at the desired position for a fixed period and does not sink.</p> <p><input type="checkbox"/> Check that no oil has dripped on the top of the base and oil is not seeping from the pump cover.</p>	<p><input type="checkbox"/> Perform the procedures indicated in "(3) Reclining and Raising the Backrest" under "Use Procedures" (p. 20-21). If operation is still not normal, it might not be possible to safely get in and out of the chair. Stop using the chair, turn off the power, unplug the power plug, and contact Takara Belmont or its distributors.</p> <p><input type="checkbox"/> Perform the procedures indicated in "(3) Reclining and Raising the Backrest" under "Use Procedures" (p. 20-21). If operation is still not normal, it might not be possible to safely get in and out of the chair. Stop using the chair, turn off the power, unplug the power plug, and contact Takara Belmont or its distributors.</p> <p><input type="checkbox"/> Perform the procedures indicated in "1. Rotate the chair so that the customer can be easily seated on the chair." of "(1) Guiding Customers" under "Use Procedures" (p. 16). If operation is still not normal, it might not be possible to safely get in and out of the chair. Stop using the chair, turn off the power, unplug the power plug, and contact Takara Belmont or its distributors.</p> <p><input type="checkbox"/> If there is any wobbling or abnormal noise when operating the chair, stop using the chair, turn off the power, unplug the power plug, and contact Takara Belmont or its distributors.</p> <p><input type="checkbox"/> Using the chair in such condition can result in abnormal operation or fire. Stop using the chair, turn off the power, unplug the power plug, and contact Takara Belmont or its distributors.</p> <p><input type="checkbox"/> If the chair does not stop for a fixed period and sinks, stop using the chair, turn off the power, unplug the power plug, and contact Takara Belmont or its distributors.</p> <p><input type="checkbox"/> Oil might be leaking from hydraulic parts. Stop using the chair, turn off the power, unplug the power plug, and contact Takara Belmont or its distributors.</p>

# Specifications

Model No.	AB-MF
Weight	135 kg
Maximum lifting capacity	1350 N (135 kgf)
Usage environment	Temperature 0 - 40°C Humidity 10 - 95% (No condensation) Air pressure 700 - 1060 hPa Use the product at an altitude of 3000m or less.
Transportation / Storage environment	Temperature -20 - 70°C Humidity 10 - 95% (No condensation) Air pressure 700 - 1060 hPa

Rated voltage	AC 230 V
Rated frequency	50 Hz
Rated consumption current	2.2 A

## ■ Legrest-Footrest Linked Type

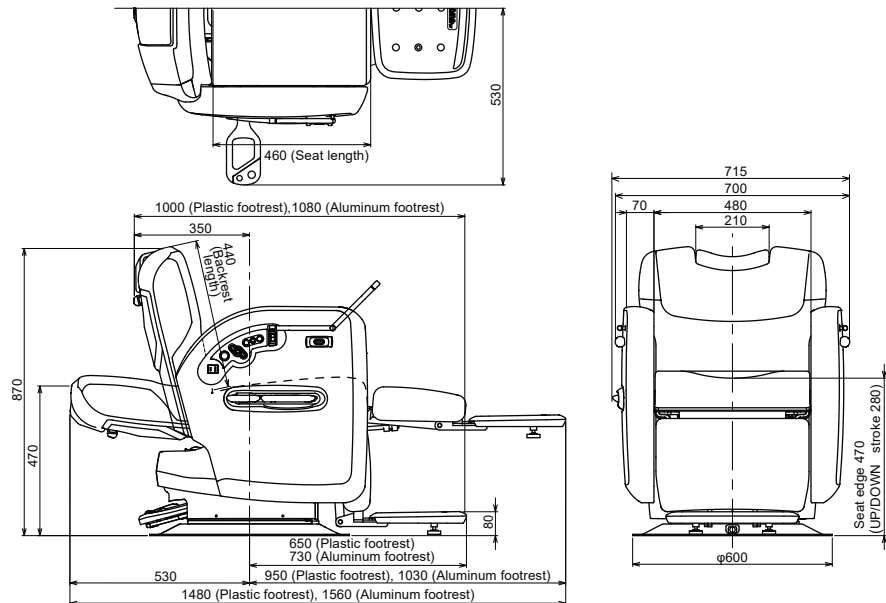

## ■ Independent Legrest Type

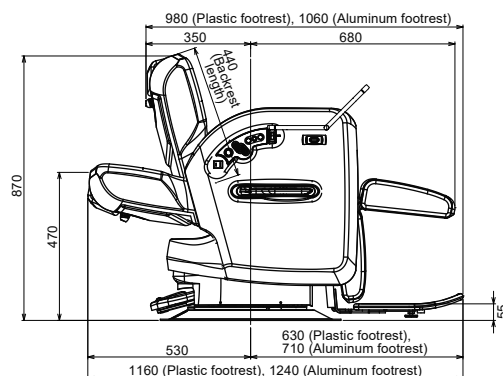

\*Dimensions and specifications are subject to change without notice due to design improvement. Standard values are indicated (Unit: mm).

## Standard Use Period

- The standard use period of this chair is 10 years.
- The standard use period is "an approximate standard period for which the chair can be safely used with no impediments to safety under the standard use conditions for each chair and while performing proper maintenance and inspection (including parts replacement). This is not a warranty period. The length of the "standard period" differs depending on the use environment and frequency of use of the customer.

## Disposing of this Product

When disposing of this product and parts replaced, handle them properly in accordance with the relevant laws and regulations (applicable regulations and local regulations).

In the EU area, EU Directive 2012/19/EU (Directive on Waste Electrical and Electronic Equipment [WEEE Directive]) applies to this product.

Environment-conscious recycling/disposal is mandatory under this Directive.

## Declaration of Conformity

### EU Declaration of Conformity

We hereby declare that the product listed below complies with the essential requirements of the EMC (electromagnetic compatibility) Directive:2014/30/EU, Low Voltage Directive:2014/35/EU, Machinery Directive:2006/42/EC and RoHS Directive:2011/65/EU based on category 11 of Annex I.

Product : BARBER CHAIR

Model : LUAR

The product has been designed and manufactured in accordance with the European standards as the listed in the Declaration of Conformity.

### UK Declaration of Conformity

We declare under sole responsibility that the device that is covered by the present declaration is in conformity with the following regulations and, if applicable, with any other relevant UK legislation that provides for the issuing of an UK declaration of conformity.

Product : BARBER CHAIR

Model : LUAR

Regulations this product conforms to:

The Electrical Equipment (Safety) Regulations 2016, S.I. 2016/110

The Electromagnetic Compatibility Regulations 2016, S.I. 2016/1091

The Supply of Machinery (Safety) Regulations 2008, S.I. 2008/1597

The Restriction of the Use of Certain Hazardous Substances in Electrical and Electronic Equipment Regulations 2012, S.I. 2012/3032 based on category 11 of PART 1, SCHEDULE I

## Intended use of the product

This product is intended for the exclusive use in hair salon for their treatment and service, and must be operated or handled by the qualified/professional hairdressers or by their staffs under the supervision of hairdressers.

Such hairdressers or staffs should instruct and/or assist the salon customers to approach to and leave from the product.

Salon customers should not be allowed to operate or handle the product unless he or she is so instructed.

## NOTE

# IMPORTER INFORMATION

COUNTRY		REGISTERED PLACE OF BUSINESS & ADDRESS
GBR	Importer in UK	TAKARA BELMONT(U.K.)LTD. BELMONT HOUSE, ONE ST.ANDREWS WAY, BOW LONDON E3 3PA, ENGLAND
DEU	Importeur in Deutschland	TAKARA COMPANY EUROPE GmbH BERNER STRASSE 18, 60437 FRANKFURT/M,GERMANY
FRA	Importateur en France	TAKARA COMPAGNIE PARIS S.A.R.L. 56 rue des Hautes Pâtures 92009 NANTERRE Cedex France
ITA	Importatore in Italia	TAKARA BELMONT ITALY S.R.L. Via Marino Mazzacurati No.4/1, 42019 Scandiano RE, Italy

EU Authorised representative

TAKARA COMPANY EUROPE GmbH  
Berner Strasse 18, 60437  
Frankfurt am Main, Germany  
TEL : +49 69 506878 0 / FAX : +49 69 506878 20



UK Authorised representative

Takara Belmont (U.K.) Ltd.  
Belmont House, One St. Andrews Way, Bow  
London E3 3PA, U.K.  
TEL : +44-20-7515-0333 / FAX : +44-20-7987-3596



MANUFACTURER



TAKARA BELMONT CORPORATION  
2-1-1, Higashishinsaibashi, Chuo-ku, Osaka, 542-0083, Japan  
TEL : +81-6-6213-5945 / FAX : +81-6-6212-3680