

Takara Belmont Far-Infrared Hair Processor

CARE DRY G

Model **AK-DRYS***

Assembly Instructions

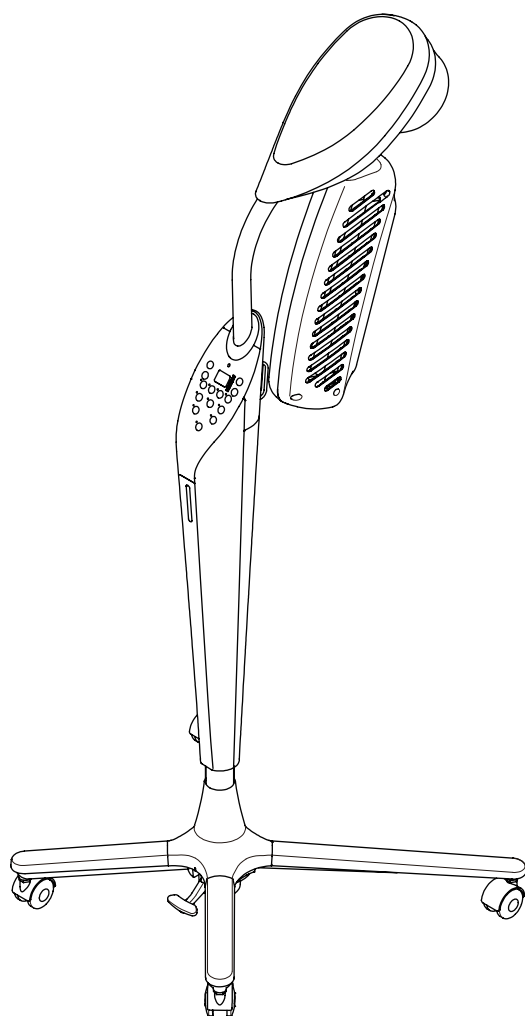

2023.07 1st Version

Request No.1E07PSA0

Before assembly:

Please make sure that all the parts are included in the kit.
Prepare a Phillips screwdriver (PH2) for assembly.



CAUTION

The heater unit requires careful handling. Do not hold it when taking the upper main unit out of the packing case or assembling the product.

Parts included in the kit:

■ Care Dry G main unit

- 1 upper main unit



- 1 power cord

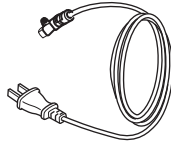

- 1 pan head screw
M3 x 15 (with a flat washer
and a spring washer)



- Power cord stopper •• 1 piece



■ Care Dry G stand

- 1 four-legged stand

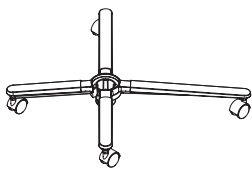

- 1 height-adjustment pipe

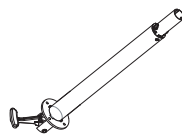

- 4 cap bolts
M5 x 15 (with spring
washers)



- 1 stand cover

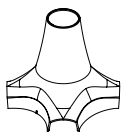

- 1 weight

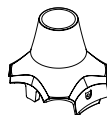

- 2 cap bolts
M5 x 15
(with anti-loosening coating
and spring washers)



Blue

- 1 hex key
* Short side: 4 mm

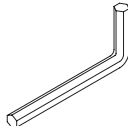

For use by delivery personnel only

Assembly steps:

■ Assembling the Care Dry G stand

(1) Loosely screw the height-adjustment pipe to the four-legged stand.

(2) Place the weight and align the height-adjustment pipe.

(3) Fully tighten the screws to fasten the height-adjustment pipe to the four-legged stand.

(4) Attach the stand cover.

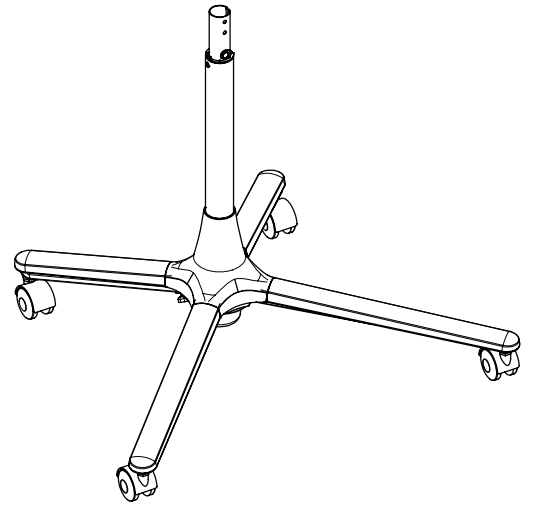

■ Assembling the Care Dry G main unit

(5) Insert the upper main unit into the height-adjustment pipe.

(6) Screw the upper main unit onto the height-adjustment pipe.

(7) Connect the power cord.

(8) Assembly is completed. (Perform an operation check.)

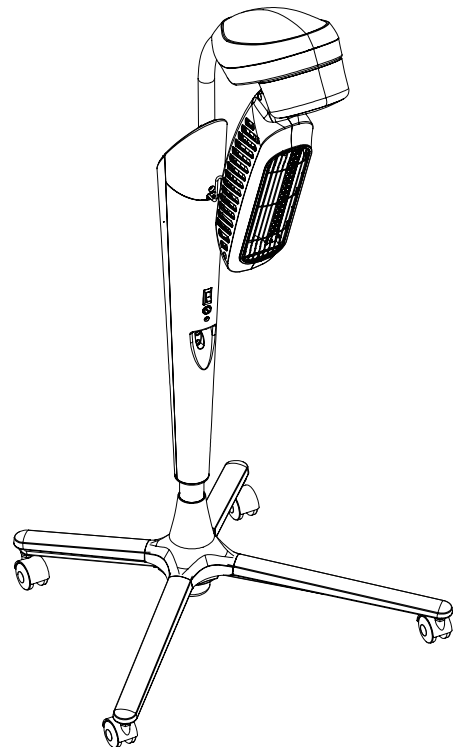

Assembling the Care Dry G Stand

(1) Loosely screw the height-adjustment pipe to the four-legged stand.

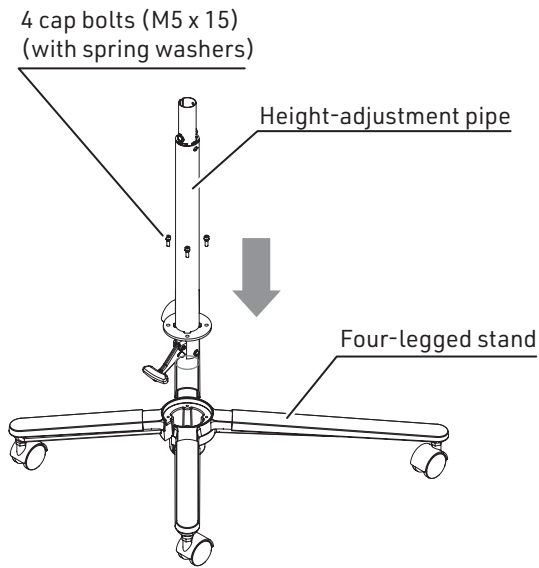

Insert the height-adjustment pipe into the four-legged stand. Loosely attach them together with the four screws provided.

* Use the provided hex key to turn the screws.

IMPORTANT

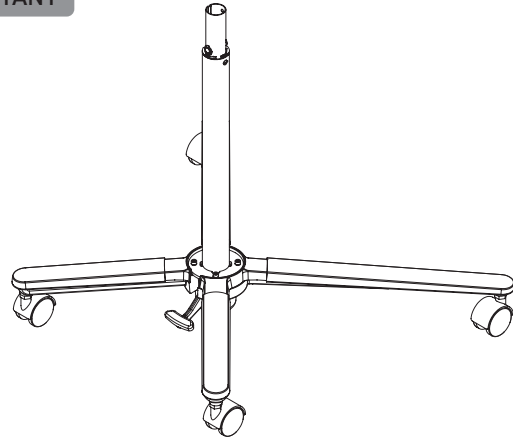

Make sure that the height-adjustment pipe can be laterally shifted with respect to the four-legged stand by the diameter of the screws.

* You will align them in the next step.

(2) Place the weight and align the height-adjustment pipe.

The weight should be attached in a certain direction. Orient it as shown in the figure below.

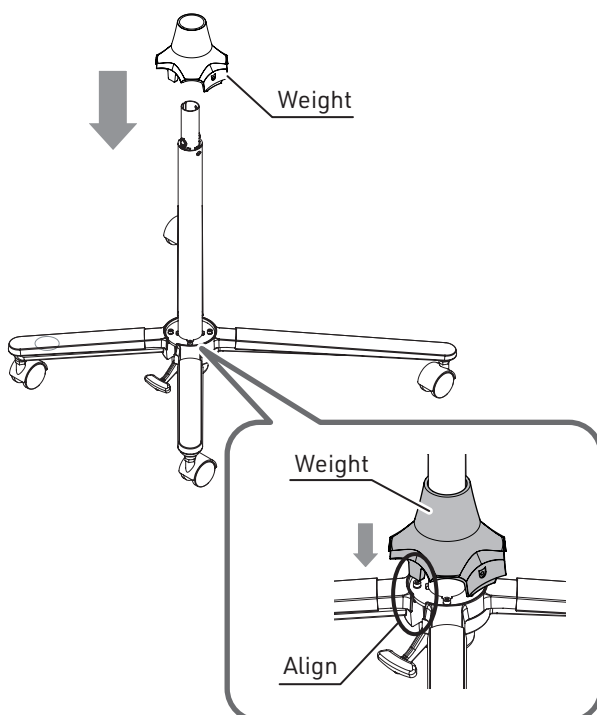

IMPORTANT

Make sure that the weight firmly fits in the four-legged stand.

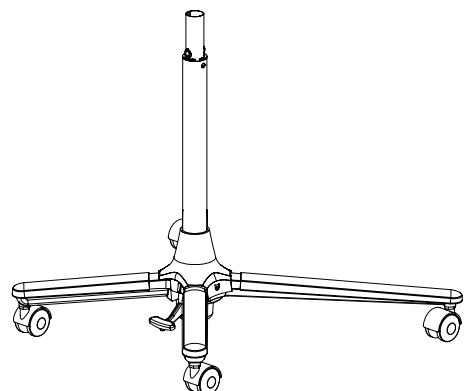

Assembling the Care Dry G Stand

(3) Fully tighten the screws to fasten the height-adjustment pipe to the four-legged stand.

CAUTION

- Make sure that the weight is properly oriented. Otherwise, when you attach the stand cover at the end, it will not fit in place.
- Be sure to tighten the screws firmly. Otherwise, the main unit may rattle.

After aligning the height-adjustment pipe in (2), temporarily remove the weight. Then, fully tighten the screws that fasten the height-adjustment pipe in the position that allows the weight to properly fit in.

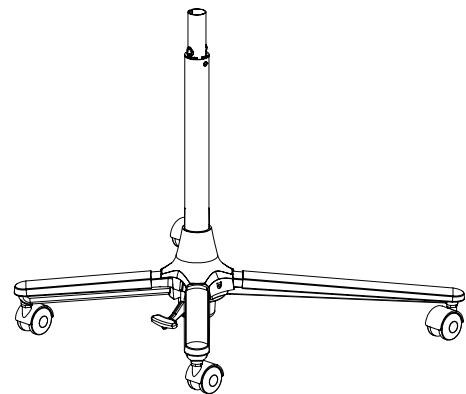
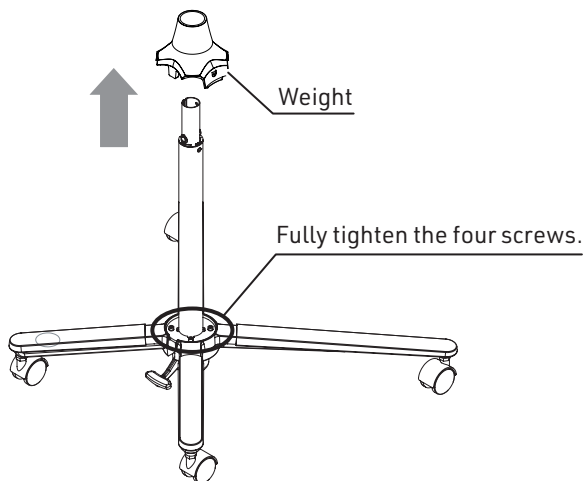

After tightening them up, attach the weight again.

(4) Attach the stand cover.

Pass the stand cover through the height-adjustment pipe and fit it into the stand. The stand cover should be attached in a certain direction. Orient it as shown in the figure below.

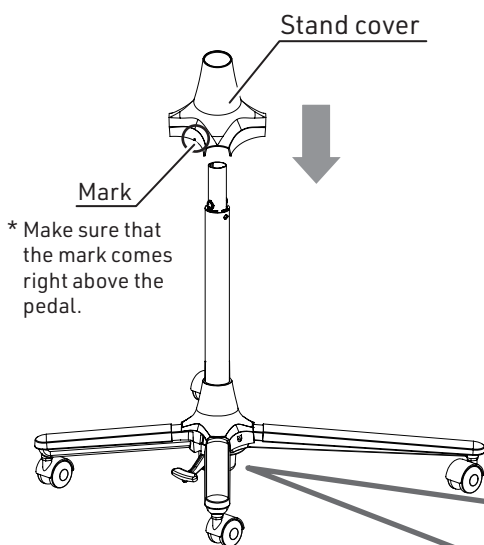

* As shown in the figure above, attach the stand cover so that the hooks on the back side catch the stand.

Eight catches on the stand cover

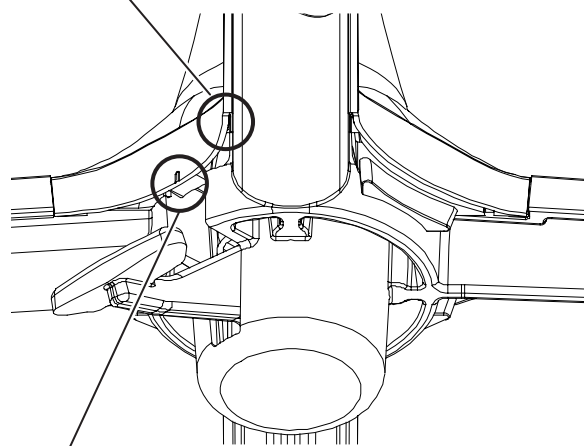

Assembling the Care Dry G Main Unit

(5) Insert the upper main unit into the height-adjustment pipe.

* When inserting the upper main unit, do not hold it by the heater unit. Hold it by the shaft or the cover of the upper main unit instead.

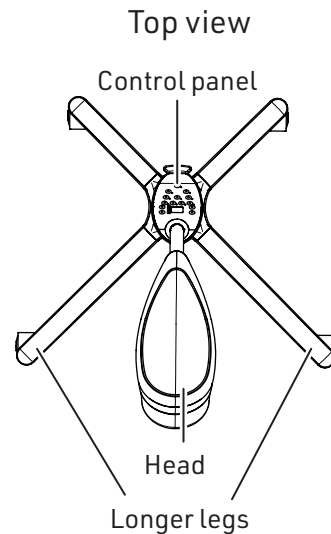
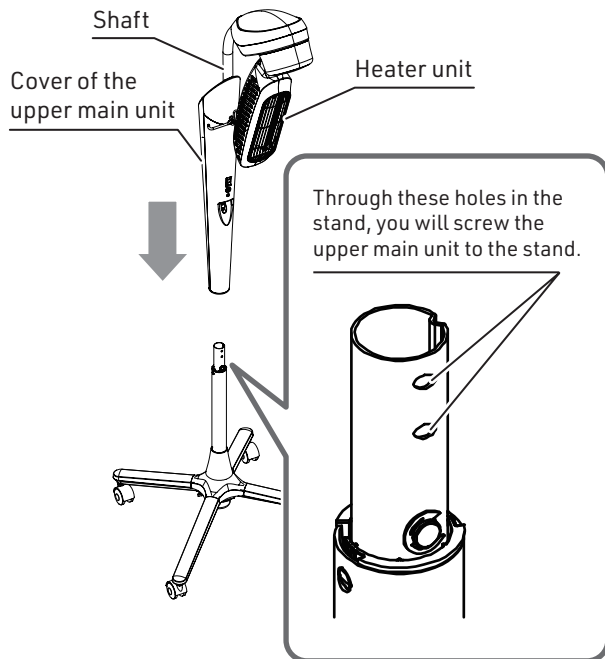

IMPORTANT

Align the Care Dry G main unit with the Care Dry G stand. Then, move on to "(6) Screw the upper main unit onto the height-adjustment pipe."

CAUTION

These holes are elongated to allow later adjustment of the orientation of the Care Dry G main unit with respect to the Care Dry G stand.

Check before tightening the screws:

After inserting the upper main unit into the height-adjustment pipe, lock the four-legged stand and shift the upper main unit slowly to the right and left.

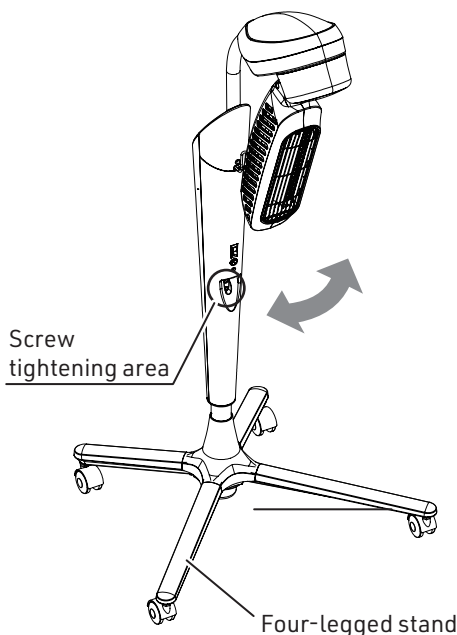

IMPORTANT

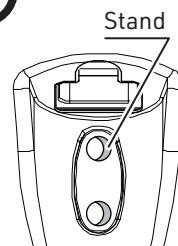

When you slide the upper main unit, the screw holes become open or closed. (The screw holes are open when those in the main unit align with those in the stand.)



Move on to "(6) Screw the upper main unit onto the height-adjustment pipe."

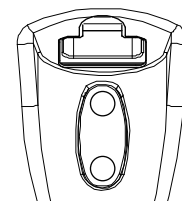

When you slide the upper main unit, the screw holes remain open and they do not become closed.



The main unit is not properly inserted into the height-adjustment pipe. Recheck the orientation of the upper main unit with respect to the stand, and insert the main unit again.

Assembling the Care Dry G Main Unit

(6) Screw the upper main unit onto the height-adjustment pipe.

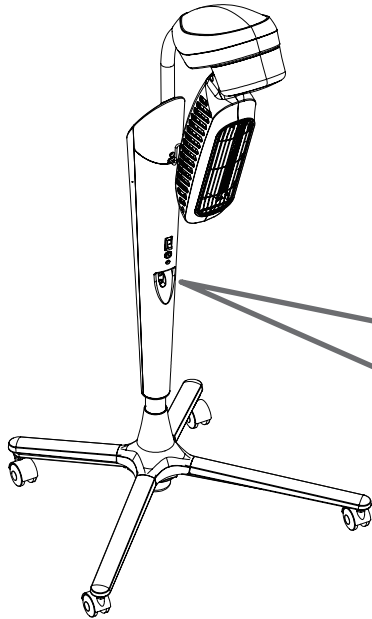

2 cap bolts (M5 x 15)
(with anti-loosening coating and spring washers)

Align the screw holes in the upper main unit with those in the height-adjustment pipe. With the two screws provided, loosely secure the upper main unit. Then, align the center of the upper main unit with that of the stand, and then fully tighten the screws.

* Use the provided hex key to turn the screws.

CAUTION

Be sure to tighten the screws firmly. Otherwise, the main unit may rattle.

CAUTION

Be sure to use the provided screws with anti-loosening coating. If you use screws without the coating, the main unit may become loose.

(7) Connect the power cord.

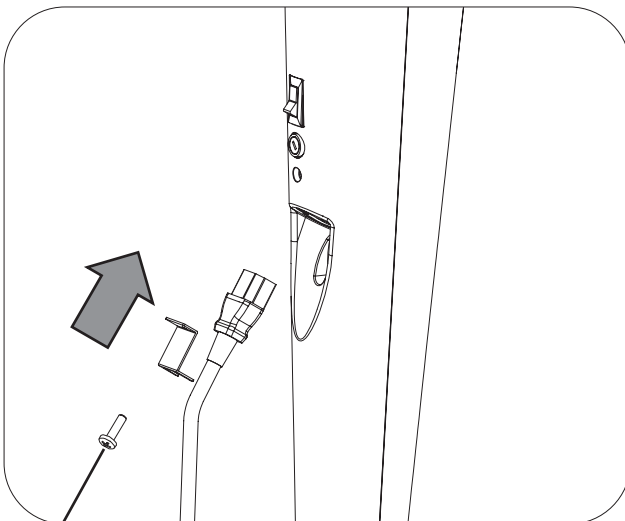

1 pan head screw, M3 x 15
(with a flat washer and a spring washer)

Fix the cord at the power cord stopper at one point with the supplied screw.

* Use the Phillips-head screwdriver.

(8) Assembly is completed.

* Check that the product works properly.

* Make sure that the center of the upper main unit is aligned with that of the stand. If they are not aligned with each other, go back to (6) to realign them and tighten the screws.

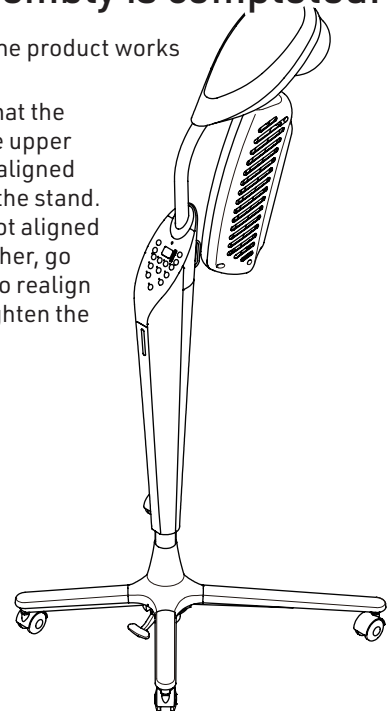

* Step on the pedal to check that the main unit goes up and down properly.

Post-assembly Operation Check Steps

Control panel:

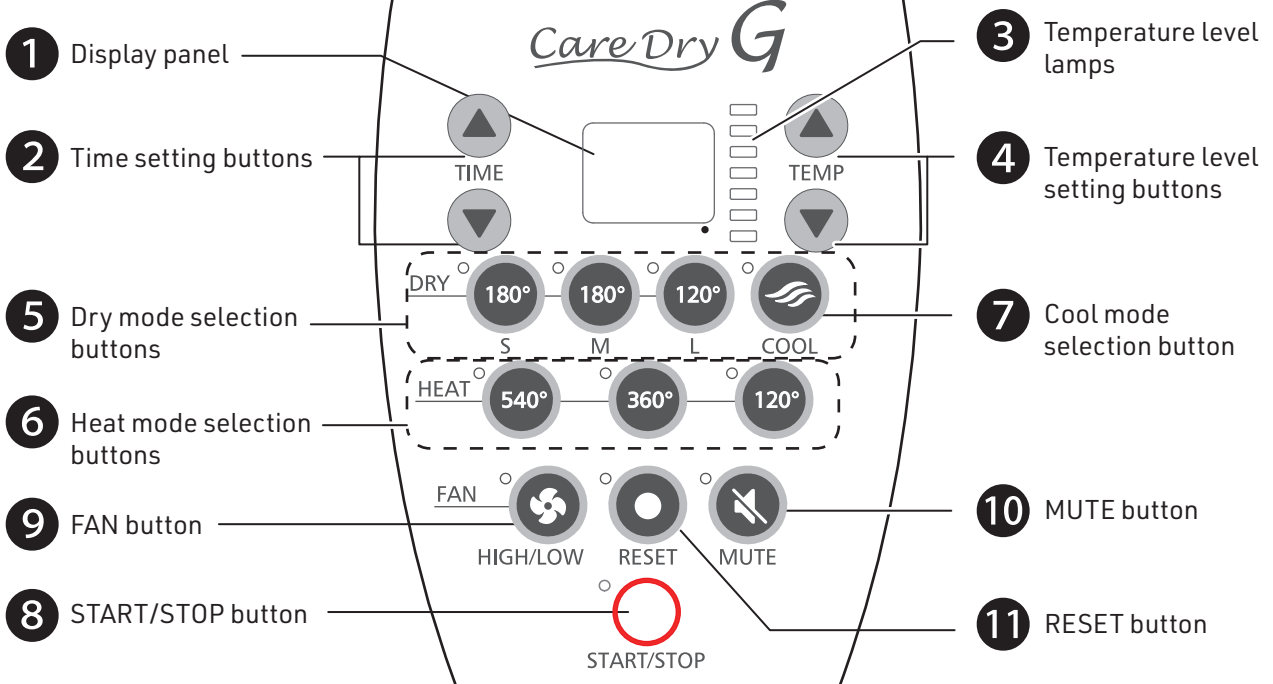

Operation check steps:

After unpacking, assembling, and installing the product, check that it works properly in the order of (1) to (2) as shown below.

(1) Initial state check

- Turn on the power switch of the product. Make sure that all the indicator lamps on the control panel immediately light up and remain on for one second.
- * After one second, the six lamps next to the dry, heat, and cool mode selection buttons will blink.

(2) Heater unit operation check

- Among the heat mode selection buttons, press the MANUAL button.
 - Press the START/STOP button once.
 - Make sure that the heater unit starts rotating and heating and that the fan starts blowing.
 - The status indicator lights up (in blue).

When all these operation check steps are completed, your Care Dry G is ready to use.