

YUME HEADBATH

Model number: **AY-YHBYM*/AY-YHBSS***

Operating Instructions

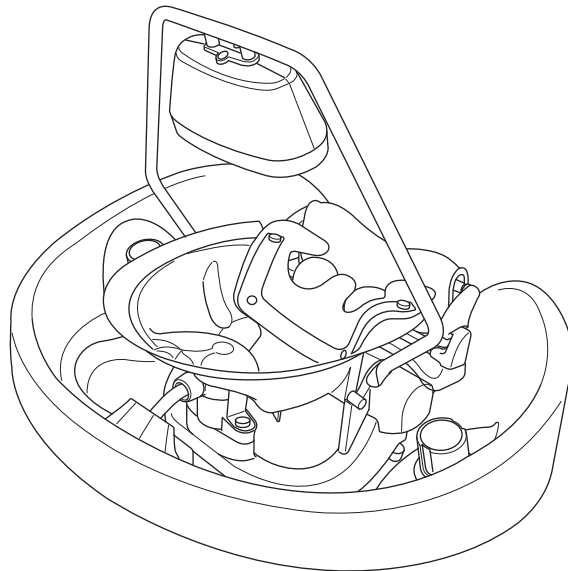

(AY-YHBYM* shown in the figure)

Instruction manual
Video (about 4 minutes)



<https://beauty.takarabelmont.co.jp/yume-headbath-videos/>

Thank you for purchasing this Takara Belmont product.

Please read the Operating Instructions carefully before use and use the product correctly.

Failing to read the Operating Instructions before use may lead to accidents.

- Keep this booklet safe near the product so that it can be referred to promptly, and be sure to read this booklet again when necessary.
- This product is an industrial appliance designed for use by hair and beauty salons. Only use this product for its intended purpose.
- The product must only be used by professionals such as hair stylists and aestheticians.

If the Operating Instructions become illegible due to stains and tears, or if this booklet is misplaced, please request a copy from Takara Belmont using the inquiry number shown in the box below.

Table of Contents

Introduction

Description of Warning Symbols	3
Safety Precautions	4
Precautions for Use	6
Accessories	7
Names of Parts	8

Preparation

Device Setup	9
Customer Setup	10
Nozzle Arch Setup	11
Inner Bowl Setup	12

How to Use

Performing Treatment	12
After Treatment	15

Maintenance

Maintenance Method	17
--------------------------	----

Information for Use when Needed

Daily Inspection	19
Standard Period of Use	19
Consumable Goods	20
Disposal of the product	21
Specifications	21
Product Dimension Diagram	22

Description of Warning Symbols

■ Before using the product ...

Please be sure to read the Safety Precautions and Precautions for Use carefully and use the product correctly.



■ Precautions shown on this page

These are intended for the safe use of the product and to prevent harm and damage to users and other people.



All of the precautions shown are important details related to safety. Please be sure to follow these precautions.

If an accident occurs due to a failure to follow the Safety Precautions and Precautions for Use, Takara Belmont is not responsible for any damage or risk to the person using this product or those around them due to accidents. In this case, the person failing to adhere to the Safety Precautions and Precautions for Use will be responsible for any damage or risk incurred.

Detailed descriptions of symbols are provided below. Read and understand these symbols thoroughly before reading this manual.

Symbols	Magnitude of harm/damage and urgency
 WARNING	The items explained under this symbol are precautions that may result in deaths or serious injury from the incorrect handling of the product if the warning is not followed.
 CAUTION	The items explained under this symbol are precautions that may result in mild or moderate injury or property damage from the incorrect handling of the product if the caution is not followed.

Individual items that must be complied with are explained under the following symbols:

Symbols for prohibited items	Symbols for mandatory items
 Display for general prohibitions  Display for prohibition of disassembly, repair, and modification	 Display for general mandatory action by the user

Safety Precautions (items that must be followed)

WARNING

When using or handling the product ...



● **Avoid using hot water above 41°C in temperature**

- This may cause burns.
- Check that the thermostatic control knob of the wash unit stops at the lock position.
- Check that the set temperature for the thermostatic control knob of the wash unit is 40°C or below.

● **Keep the user's and customer's hands, fingers, bodies and pieces of clothing away from the moving parts of the product or the area around the moving parts**

This may cause injury from jamming.

● **Do not operate the chair or the wash unit during treatment**

This may lead to injury.

● **Do not use the device with products that are not listed as compatible**

Use of the device with non-compatible products may result in injury or device damage. Please refer to [page 9] for the list of compatible products.



● **Avoid disassembling, repairing, and modifying the product**

- The device must not be disassembled or repaired by people other than qualified repair technicians under any circumstances because this may result in accidents and failures.
- Modification of the product is dangerous and must be avoided under any circumstances.



● **Be sure to perform daily inspection**

The use of the product without performing daily inspections may lead to injury and product damage.

Please refer to [page 19] for the daily inspection.

● **Adjust the temperature of the hot water by checking the temperature with hands**

When adjusting the temperature of the hot water, tilt the nozzle arch towards you and adjust the temperature while checking the temperature with hands so that the hot water does not come into contact with the customer. Care must be provided because the simultaneous use of other devices that share the same source of cold or hot water may cause changes in water pressure and lead to boiling water being output.

Safety Precautions (items that must be followed)

CAUTION

When using or handling the product ...



● **Avoid drinking the hot or cold water**

This product is designed for use for head bath. Do not drink the water. Diarrhea, abdominal pain, etc. may occur depending on the water quality.

● **Avoid using the product with a damaged nozzle cover and base.**

In case of damage to the nozzle cover and base, contact your local Takara Belmont dealer immediately and have these replaced. Continued use without replacing these parts may result in failure or an accident.

● **Do not apply shock to the product**

Damage to the cover, a malfunction, or breakage may lead to injury.

● **Do not lean on the nozzle arch.**

Damage to the product, a malfunction, or breakage may lead to injury.



● **Precautions before installation**

If the customer has long hair, the hair should be held together using hair clips, etc. to avoid the hair becoming caught during product installation.

● **Precautions for product installation/removal**

- Avoid contact of the product with customers because this may result in injury.
- The product should be handled carefully with both hands near the customer. Accidental slipping and dropping of the product may cause injury to the customer or product/device breakage.

● **Precautions during treatment**

Be sure to use a face towel because water may splash onto the customer's face, or simultaneous use of other devices that share the same source of cold or hot water may cause changes in water pressure and lead to unstable water output, which may also cause the water to come into contact with the customer's face.

● **Be careful of customers and children**

- Care must be taken during use of this product to monitor the customer at all times. Sudden movement of the customer may lead to malfunctions and accidents.
- Keep children away from the product during treatment.

● **Consideration for the physical condition of customers**

The customer's head becomes warm during treatment. If the customer becomes or feels unwell, treatment should be discontinued. Care must be taken, particularly for customers who are susceptible to dizziness from heat, who have high blood pressure, or have concerns in physical conditions.

● **Support the head of the customer when lowering or raising the backrest of the chair**

When lowering or raising the backrest of the chair, be sure to support the head of the customer with your hand and call out to the customer.

● **Precautions during removal**

Flush the water from the nozzle arch then store this in the dedicated storage bag. Failure to flush the water before storage may cause water to leak and cause the device and floor to become wet.

Please refer to [page 15] for instructions on how to flush the water out.

● **Be sure to wipe the floor if it is wet**

If the floor is wet after treatment, immediately wipe the floor clean because this may lead to deterioration of the floor surface or injury from accidental slipping.

Precautions for Use

- **Do not use for any purpose other than hair and beauty salon treatment**

This product is an industrial appliance for use in hair and beauty salons. Please avoid the use of the product outside these purposes.

The product must only be used by those who have undergone appropriate training, such as hair stylists and aestheticians.

- **Be sure to secure sufficient supply of hot water**

Stable output of hot water in cascade form requires hot water supply of at least 8.6 L/min.

Special caution will be required because the use of a dual function shower head with hot/cold water supplied at a pressure of 0.1 MPa will result in a shower output rate of about 10 L/min for the YUME, YUME DX, YUME ESPOIR, YUME SWING, YUME SUITE, and YUME NOBLE, about 8.0 L/min for W SWING YUME, and about 8.5 L/min for the YUME OASIS backwash basin, and about 9.5 L/min for the YUME OASIS sidewash basin.

- **Remove the product when not in use**

Coming into contact with the product when washing the hair may result in injury.

- **Avoid holding the nozzle cover**

This may cause nozzle cover breakage.

- **Avoid applying heat of 60°C or higher**

This may result in degeneration and discolouration.

- **Wipe off any chemicals that adhere to the product**

If chemicals adhere to the product, immediately wipe these off with a dry cloth because such contact may result in degeneration and discolouration.

- **Avoid the use of mint oil and aroma oils**

This may result in degeneration and damage.

- **Avoid the use of polishing agents**

Do not use polishing agents when cleaning the product.

The use of polishing agents, sponges containing polishing agents, or hard cleaning equipment, such as wire wool and nylon scrub sponges, may cause scarring.

- **Do not use the dedicated storage bag for purposes other than product storage**

Use for purposes other than product storage may damage the bag.

- **After treatment, store the product in the dedicated storage bag and place on a flat surface**

Storage of the product in an unstable location may cause the product to fall and become damaged.

- **Shower head of the wash unit must be returned to the shower head holder so that the shower head plate is facing towards the basin**

When water is released, the hot water may spill outside the basin or come into contact with the customer.

- **Insert the shower head of the wash unit securely to the shower head holder**

If the shower head is not inserted sufficiently, it will not be held securely by the shower head holder.

This may cause the direction of the shower head to change when water is released, resulting in the water coming into contact with the customer.

- **Avoid moving the basin while the product is set to the basin**

This may cause the product to fall and break.

Precautions for Use

● **Be sure to use the neck cushion of the wash unit**

Neck cushion must be used as performing treatment without using the neck cushion may cause a burden on the neck and lead to injury.

● **Clean the hair catcher of the wash unit frequently**

The hair catchers should be cleaned as frequently as possible. Cleaning should be performed after each customer's treatment where possible because use of the device without cleaning may cause the drain to become clogged with accumulated hair and result in water overflow and unhygienic conditions.

● **Wipe off the water accumulated in the dedicated storage bag**

Water left in the bag may lead to spillage and cause the floor to become wet.

Accessories

Dedicated storage bag (with liner)

Operating Instructions: One copy
(this document)



Names of Parts

Inner bowl

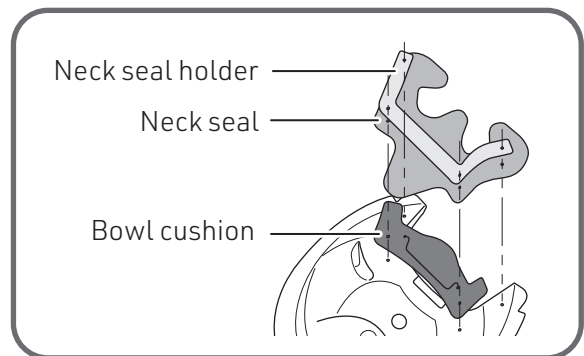
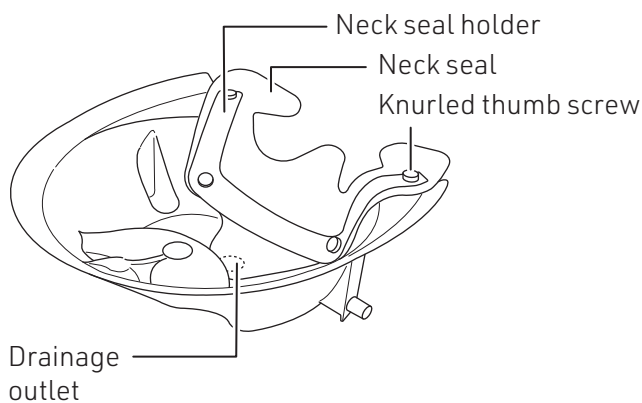

Bowl cushion

AY-YHBYMS/AY-YHBYMO/
AY-YHBSS*/AY-YHBSSS2

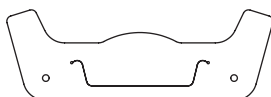

AY-YHBYMS2

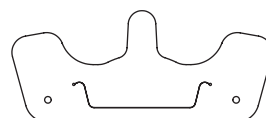

Names of Parts

Neck seal

Backwash (YUME) basin specification

AY-YHBYMS/AY-YHBYMO

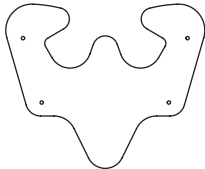

Sidewash basin/side neck specification

AY-YHBSSS/AY-YHBSSO

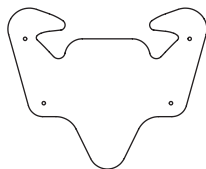

OASIS basin/backwash specification

AY-YHBYMS2

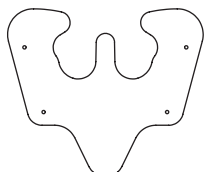

OASIS basin/sidewash specification

AY-YHBSSS2

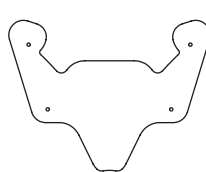

Nozzle arch

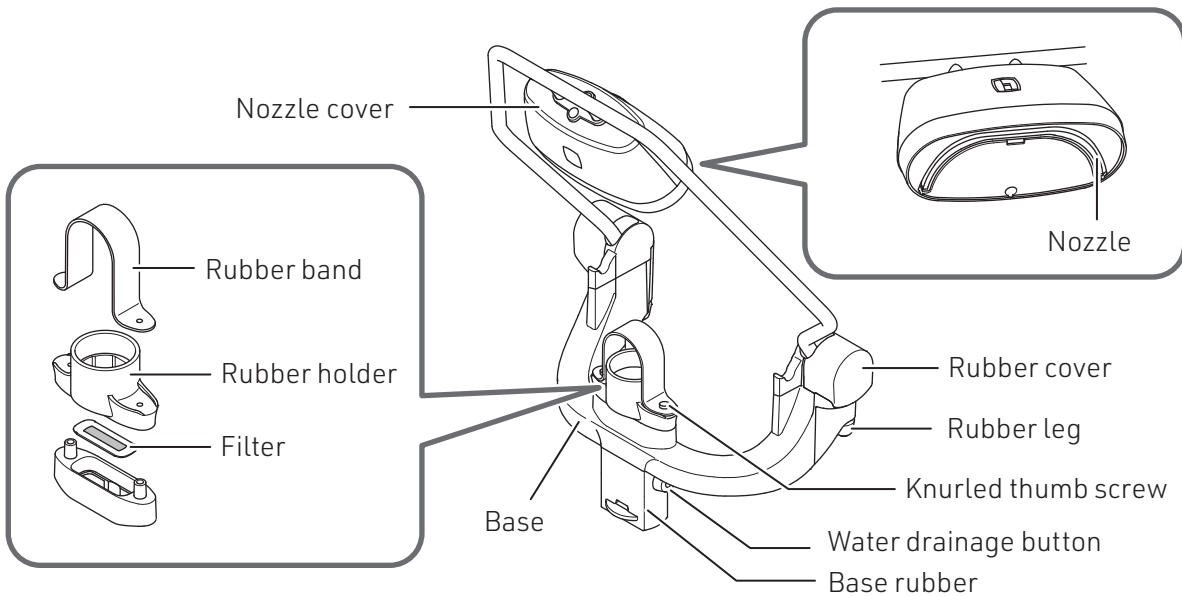

Base rubber

AY-YHBYMS/AY-YHBSSS/
AY-YHBYMS2

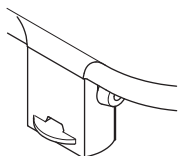

AY-YHBSSS2

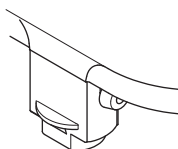

AY-YHBYMO/AY-YHBSSO

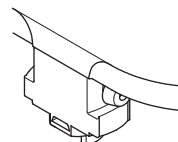

Device Setup

- This product is an accessory of wash unit for use for head bath.
- AY-YHBYMS/YMO are dedicated for use with the YUME series backwash (YUME) basin specification.
- AY-YHBSSS/SSO are dedicated for use with the YUME series sidewash basin specification.
- AY-YMS2/SSS2 are dedicated for use with the YUME series OASIS basin specification.

WARNING

Do not use the product with other products that are not listed as compatible. Use of the device with non-compatible products may result in injury or device damage.

Compatible products

- YUME
- YUME SWING
- YUME SUITE
- YUME OASIS (full lie-flat posture only)
- W SWING YUME (full lie-flat posture only)
- YUME DX
- YUME ESPOIR
- YUME NOBLE

* The product can only be used with the dual function shower head of compatible products.

* YUME OASIS and W SWING YUME are available for use in the full lie-flat posture only.

* It is not available for use with the YUME NAGOMI (IXI).

The product is used by attaching the nozzle arch and the inner bowl to the backwash (YUME) basin and sidewash basin and OASIS basin as shown in the figure below.

* Follow the setting procedure in the following sections to install the nozzle arch and inner bowl.

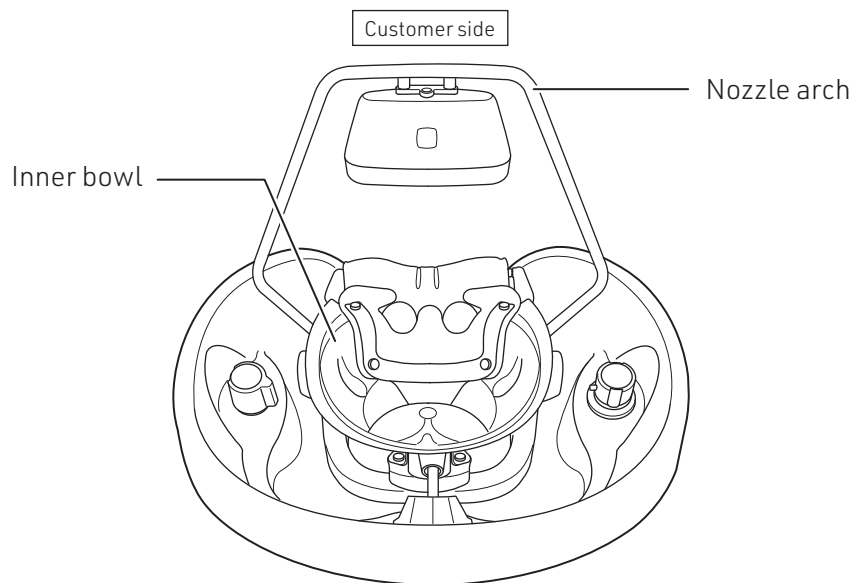

CAUTION

Avoid contact of the product with the customer when installing the product.

*Note

Please be advised that the illustrations used in this Operating Instructions are those of the AY-YHBYM*.

Customer Setup

1 Allow the customer to lie down

Support the head of the customer and gently lower the head onto the neck cushion.



CAUTION

Be sure to support the head of the customer with operator's hand when lowering the backrest of the chair to avoid injury caused by contact of the head with the basin.

2 Check that the face angle is horizontal

If the face angle is not horizontal, make fine adjustments by asking the customer to move upward or downward.

<Backwash basin>

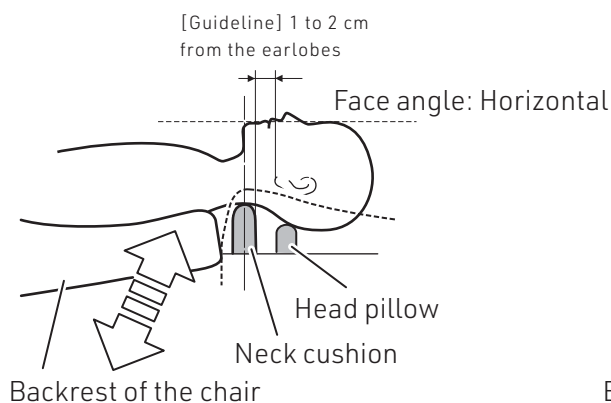

<Sidewash basin>

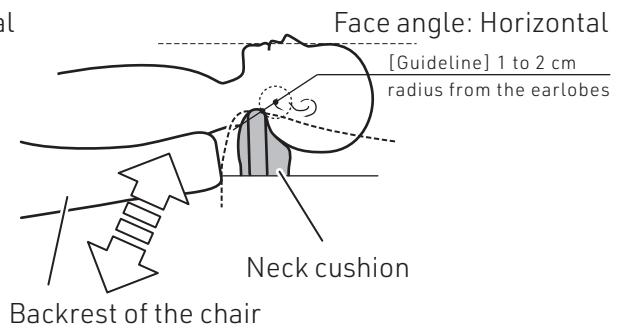

CAUTION

Deterioration in the neck cushion of the wash unit cause the cushion to lower, and this may result in the water held in the inner bowl to overflow from the side of the neck beyond the neck cushion. The neck cushion should be replaced if the level of the water in the inner bowl is reaching overflow level. Neck cushions should be considered consumable goods.

3 Wetting the customer's hair

The product must be used while the hair is wet, for example, after shampooing and rinsing the hair or after the spa cleansing process. If the hair is not wet, the hot water may splash and come into contact with the face and ears.



CAUTION

- Do not use this product to rinse off hair colour because this may lead to discolouration of the inner bowl.
- If the customer has long hair (shoulder length or longer), the hair should be held together using hair clips, etc. to avoid the hair becoming caught during product installation.

Nozzle Arch Setup

1 Remove the drain cap from the drainage outlet in the basin

The drain cap should be placed outside the basin.

2 Attach the nozzle arch

Insert the base rubber of the nozzle arch to the drainage outlet in the basin.

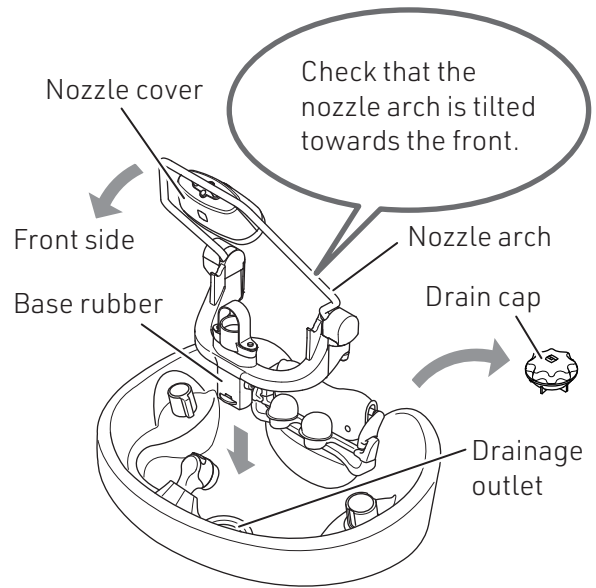

CAUTION

- Be sure to keep the customer's hair from being caught.
- Avoid contact of the nozzle arch with the customer.
- Do not hold the nozzle cover because this may lead to damage.

3 Hold the shower head with a rubber band

(i) Switch the shower head to shower mode. The amount of hot water output in low-splash foaming mode is not sufficient for cascades of water, and the head bath sensation may not be obtained.



Press the convex side of the switch to change to shower mode.

(ii) Insert the shower head into the rubber holder while holding the rubber band towards the customer side.

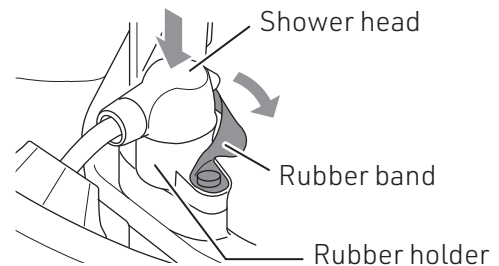

CAUTION

When inserting the shower head into the holder, pull the shower head straight out before inserting it into the holder. The shower hose may break if it is bent forcibly.

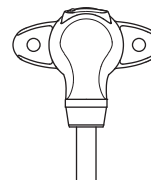

Backwash (YUME) basin / Sidewash basin

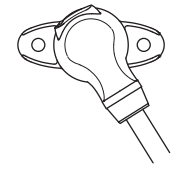

OASIS basin

(iii) Return the rubber band to hold the shower head.

CAUTION

If the shower head is not secured properly with the rubber band, the shower head may become displaced and cause hot water to splash into the surrounding area.

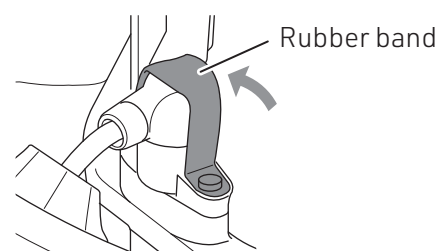

Inner Bowl Setup

Attach the inner bowl

Lift the customer's head and place the convex part of the inner bowl on top of the concave part of the rubber cover on both the right and left sides to attach the inner bowl.

* Check that neck seal is not folded, as this may prevent the water from being held in the basin.

CAUTION

- Be careful not to get the customer's hair caught during setup.
- Avoid the inner bowl coming into contact with the customer

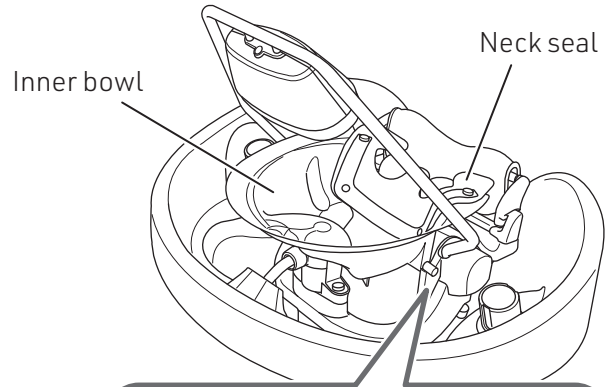

Convex part of the inner bowl

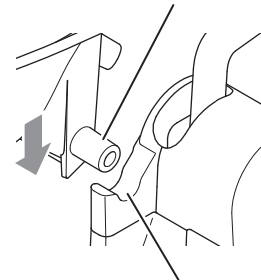

Concave part of the rubber cover

Performing Treatment

CAUTION

Be sure to use a face towel because hot water may splash the customer's face, or simultaneous use of other devices that share the same source of cold or hot water may cause changes in water pressure and lead to unstable water output, which may also cause the hot water to come into contact with the customer's face.

- 1 Check that the nozzle arch is tilted towards the front**

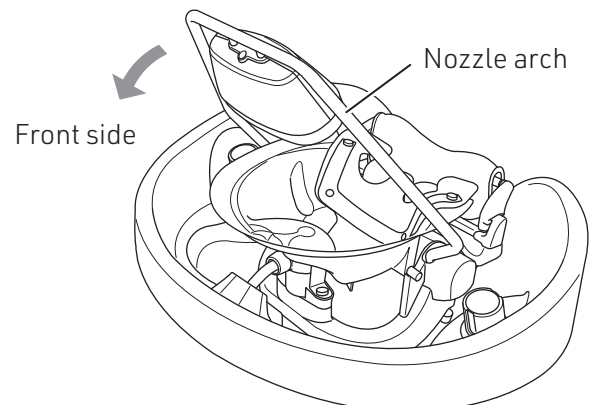

Performing Treatment

2 Pour hot water in the inner bowl

- (i) Check that the set temperature for the thermostatic control knob of the wash unit is 40°C or below.
- (ii) Fully open the tap on the wash unit.
- (iii) Check the hot water temperature with hands.
- (iv) To make the water output stable, wipe the nozzle with a finger while taking care to avoid wetting the customer's face.

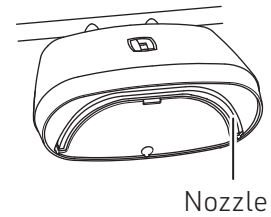

WARNING

When adjusting the temperature of the hot water, tilt the nozzle arch towards you and adjust the temperature while checking the temperature with hands so that the hot water does not come into contact with the customer. Care must be provided as the simultaneous use of other devices that share the same source of cold or hot water may cause changes in water pressure and lead to hot water being output.

CAUTION

Hot water with a temperature different from the temperature setting may spout due to residual water in the piping. Hot water at an inappropriate temperature should be discharged through the drain outlet in the inner bowl. Please refer to [page 15] for how to drain the water.

3 Once a certain amount of hot water is contained in the inner bowl, lift the nozzle arch towards the customer and adjust the water outlet to the side of the face line.

CAUTION

- Do not make adjustments by holding the nozzle cover because this may cause damage.
- If the nozzle arch is moved too close to the customer, this may result in hot water entering the ears. Be sure to check the position while adjusting.

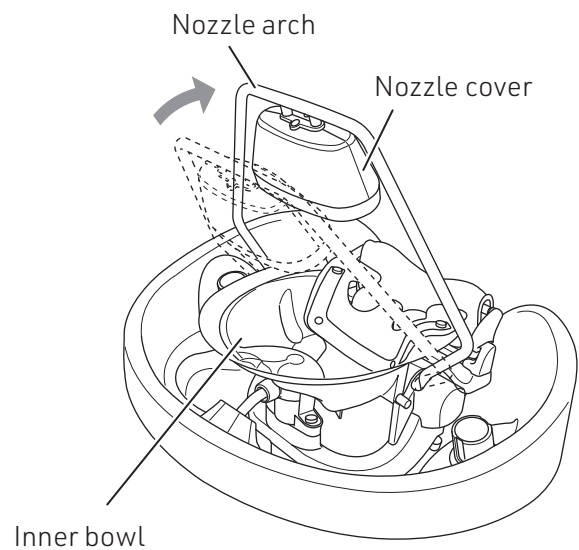

Performing Treatment

4 Perform head bath

Adjust the angle of the nozzle arch while checking the state of water output.



CAUTION

- Care must be taken during use of this product to monitor the customer at all times. Sudden movement of the customer may lead to malfunctions and accidents.
- The customer's head becomes warm during treatment. If the customer becomes or feels unwell, treatment should be discontinued. Care must be taken, particularly for customers who are susceptible to dizziness from heat, who have high blood pressure, or have concerns about their physical condition.
- Do not use the device after hair colouring as the fading of hair colour may be accelerated.

Head massage may be performed during treatment.



CAUTION

- Do not lift the neck of the customer off the neck cushion because this may cause wetting around the customer's neck.
- Avoid accidental contact of the hand with the nozzle arch because this may cause the customer's face or ears to become wet with hot water.
- Do not wet the shower head holder with hot water because the floor surface may become wet.

After the Treatment

1 Hold the nozzle arch and tilt to the front, then stop the water.

⚠ CAUTION

- Do not tilt the nozzle arch by holding the nozzle cover because this may cause damage.
- Stopping the water before tilting the nozzle arch to the front may cause residual hot water to come into contact with the face.

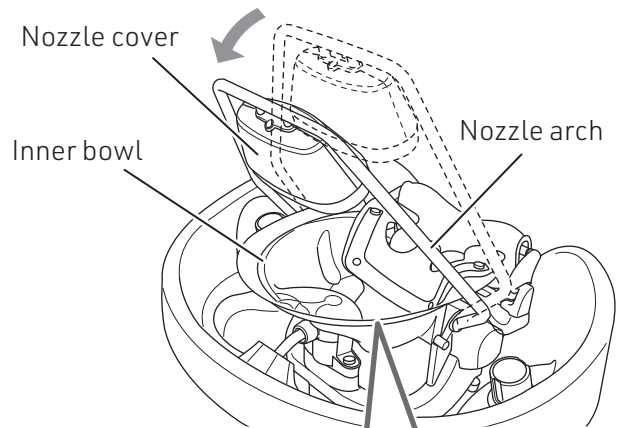

2 Drain the hot water held in the inner bowl

Lift the neck seal and drain the water through the drainage outlet in the inner bowl.

⚠ CAUTION

If the customer has long hair (shoulder length or longer), the hair should be bundled together before draining the water because the hair may become tangled during drainage.

Draining method

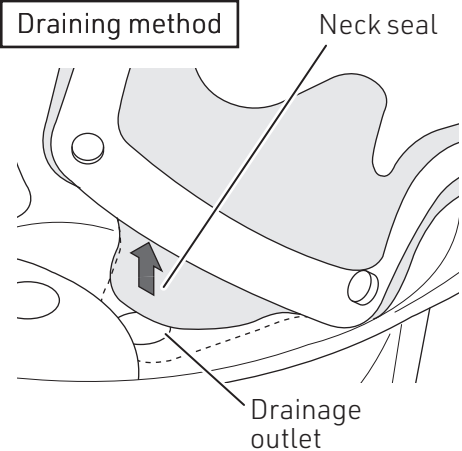

Lift the neck seal and drain the water through the drainage outlet in the inner bowl.

3 Remove the inner bowl after water is drained

The inner bowl should be stored in the pocket section of the dedicated storage bag. [See page 16]

4 Remove the shower head and return to the shower head holder

Pull the rubber band holding the shower head towards the customer side and remove the shower head.

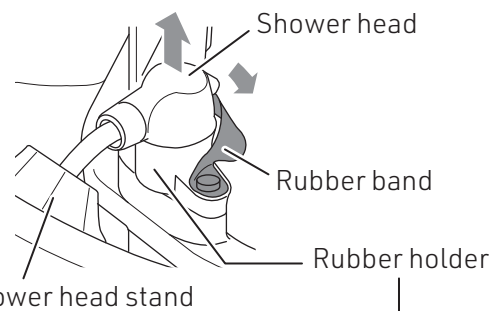

5 Drain the hot water accumulated in the nozzle arch

Press and hold the drainage button for about 10 seconds and allow the water to drain.

* Hot water accumulated in the nozzle arch must be drained after every use. Otherwise, the hot water accumulated inside the nozzle arch may spill into the bag.

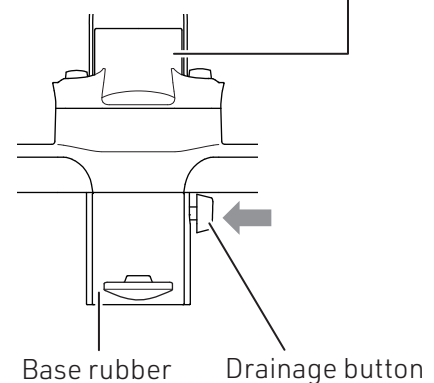

After the Treatment

6 Remove the nozzle arch

Remove the nozzle arch while avoiding contact with the customer, then store this in the dedicated storage bag. [See figure below]

* The bag is made of waterproof material; however, it is not designed to hold water. Wipe the inside of the bag to prevent an accumulation of water during use. An excessive accumulation of water may cause leakage through the stitches that may spill onto the floor.

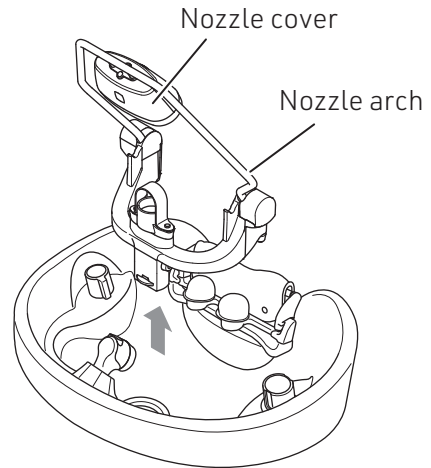

CAUTION Do not hold the nozzle cover as this may cause damage.

The dedicated storage bag, nozzle arch, and inner bowl should be dried separately after operation completion.

* Remove the liner in the dedicated storage bag and allow to dry. Accumulation of water between the bag and the liner may cause the water to spill onto the floor through the stitches.

Storage Method

*The dedicated storage bag must be used with the liner inside.

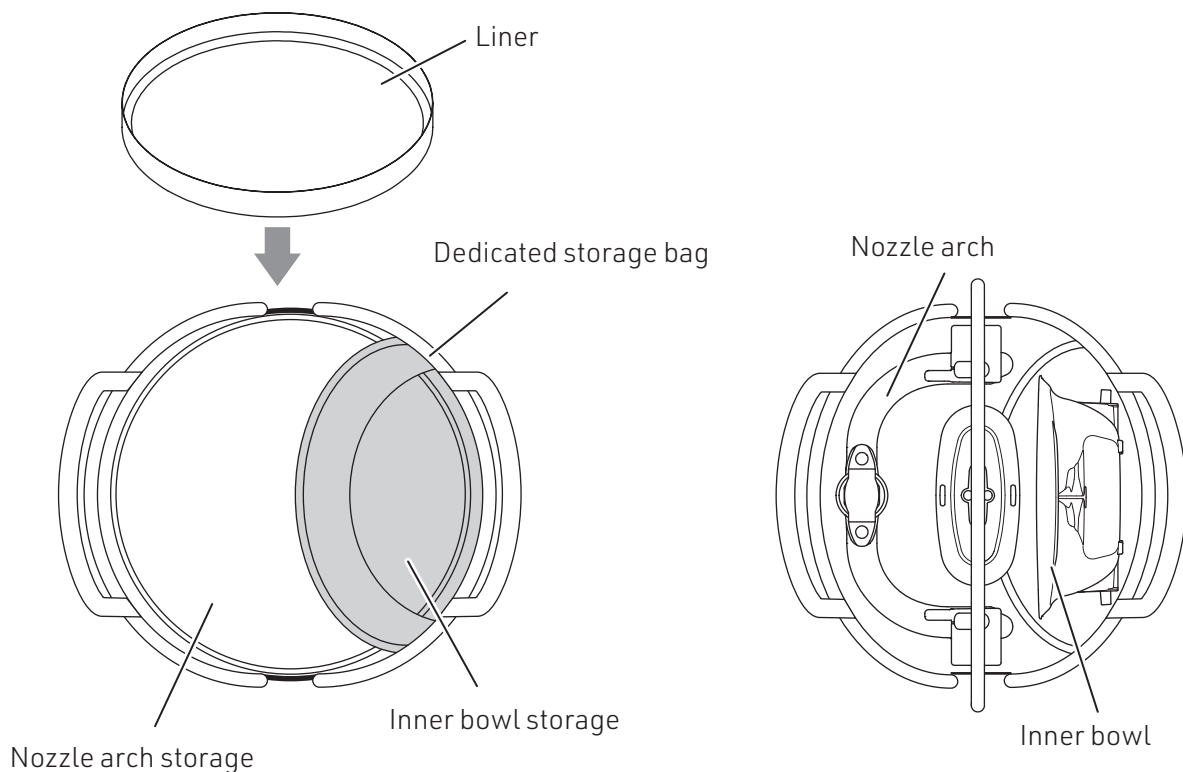

Maintenance Method

Maintenance should be performed after using the product to keep it clean at all times. Stains left uncleaned may lead to the growth of mold.

⚠ CAUTION Some of the product's metal parts and mechanical sections may be sharp. Care must be taken when handling to avoid injury to the hands and fingers.

Maintenance of Individual Parts

Wipe gently with a dry, soft cloth.

**Resin parts/
bag:**

For severe staining

Wipe with a soft cloth wet with neutral detergent diluted about tenfold with water, followed by wiping with a cloth wet with water, then carefully wipe with a dry cloth.

Metal parts:

Wipe with a dry, soft cloth.

Residual moisture may cause rust and malfunction.

- **The following materials must not be used:** Volatile chemicals, such as thinner, alcohol, remover, gasoline, and kerosene, acid, alkaline or chlorine-based detergents, antiseptic solution strongly corrosive to metals (Povidone Iodine, sodium hypochlorite, etc.), waxes containing abrading agent, sponges containing abrading agent and scrubbing brushes, or other cleaning tools.
- **Do not use brushes and scrubbing brushes for maintenance of the product because this may cause scarring and make the stains more difficult to remove.**

Cleaning must be performed if the product is being reused after a period of non-use. Also, be sure to check that the product operates correctly after cleaning.

Rubber Cover

If the rubber cover becomes displaced, re-attach at the sections shown with the shaded circles ●

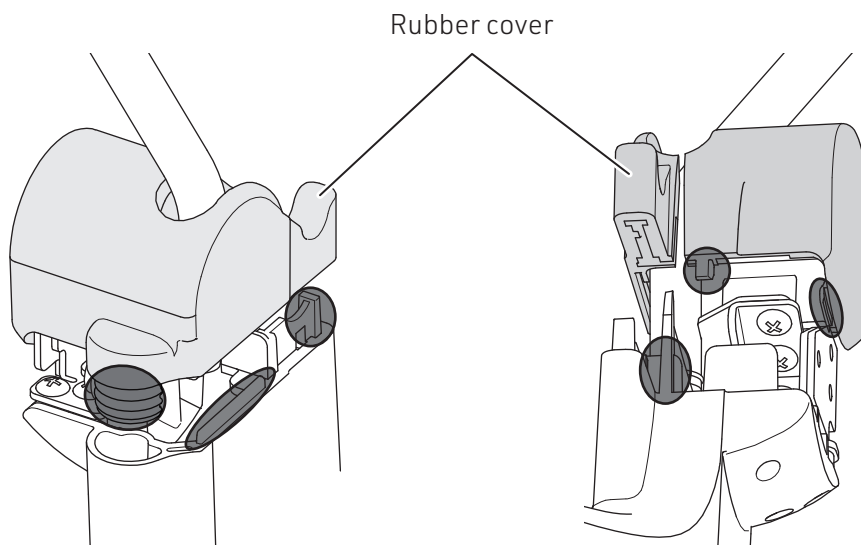

Maintenance Method

Filter

1 Remove the Knurled thumb screw, rubber band, rubber holder, and the filter and clean the filter

Remove the filter by lifting the edge of the filter with the fingers.

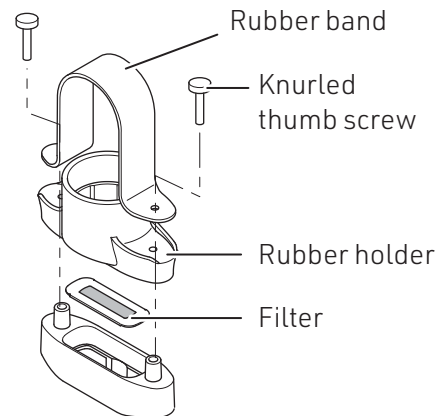
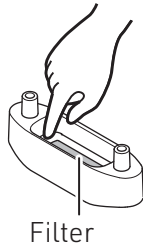

2 Attach the filter to the rubber holder

Attach the filter to the rubber holder with the front side facing the rubber holder.

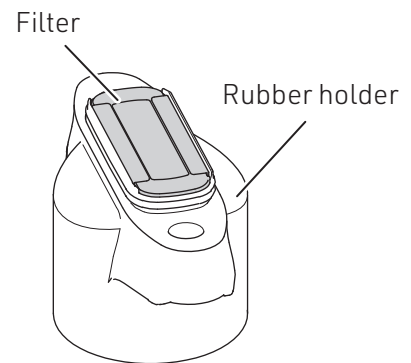

CAUTION

Be sure to install the filter to prevent contamination of the pipes with foreign matter.

[Key point]

Attach the filter by holding the filter with the edge of the rubber holder. Placing the rubber holder as shown below will allow the filter to be held securely.

- (i) Secure the filter into the rubber holder and press
- (ii) Push the edge of the rubber holder from both sides.

Edge of the rubber holder

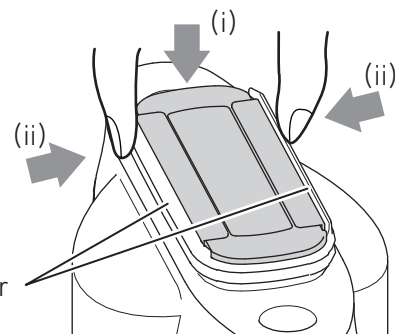

3 Attach the rubber holder, rubber band, and Knurled thumb screw

Daily Inspection

The following inspection should be performed for safe use of the product.



WARNING

Daily inspections must be performed according to the details shown below. Use without performing daily inspections may lead to injury and damage to the product, accessories, and facilities.

Daily inspection items

Inspection item	Inspection method	Inspection result, action to take in case of failure
State of water output	Fully open the tap on the wash unit and check for division of the water stream.	Check that the shower head switch is on shower mode. If the water stream continues to divide after wiping the nozzle with a finger and after cleaning the shower head or the filter, discontinue use and contact your local Takara Belmont dealer.
Angle of nozzle arch	Check that the nozzle arch stops at the desired position	Discontinue use and contact your local Takara Belmont dealer.
Fixation of the shower head	Hold the shower head with the rubber band and check that the shower head is held securely.	The rubber band and/or the rubber holder may be worn out. Discontinue use and contact your local Takara Belmont dealer. Rubber bands and rubber holders are considered consumable goods.
State of the neck seal	Check for any tears or deformations	The neck seal should be replaced. Neck seals are considered consumable goods.

Standard Period of Use

- The standard period of use for this product is three years.
- Standard period of use is defined as "a guideline for the standard period of using the product without any problems in safety under standard conditions of product use with appropriate maintenance and inspection (including replacement of parts) performed." Please be advised that this is not an indication of the guarantee period, and the standard period will differ depending on the environment (including water quality) and method in which you use the product. Please contact your local Takara Belmont dealer for maintenance after completion of the standard period of use.

Consumable Goods

“Consumable goods” refer to parts that are expected to undergo wear, deterioration, and changes/damage in appearance with use. Please be advised that the repair and replacement of consumable goods are not covered under the guarantee and will incur a charge.

(*Degree and timing of wear, deterioration, and damage varies depending on the environment (water quality, etc.) and conditions the product is used.)

In the case of significant wear and deterioration or damage, inspection or replacement of the parts will be necessary. Please contact your local Takara Belmont dealer immediately.

Consumable goods (the following items are not covered under the guarantee and incur a charge)

- Rubber band Rubber holder Inner bowl Neck seal
- Dedicated storage bag

Also, scars, stains, deterioration, and discolouration on the outer surface of the exterior parts (metal parts, resin parts, etc.) are not covered under the guarantee.

Replacement of Consumable Goods

Rubber band

Remove the Knurled thumb screw and replace the rubber band or the rubber holder.

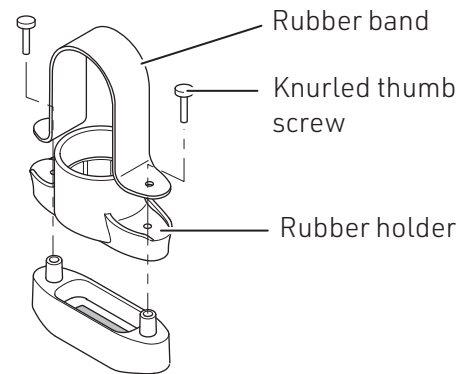

Rubber holder

Remove the Knurled thumb screw and replace the rubber holder.

*Be sure to install the filter. [See page 18]

Inner bowl/neck seal

(i) Remove the Knurled thumb screw and replace the neck seal or the inner bowl.

*The neck seal holder should be attached with the smooth side on top.

(ii) Bring the notch section (round section) of the bowl cushion to the outside of the inner bowl.

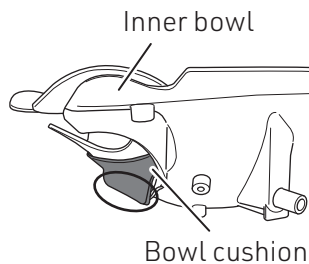
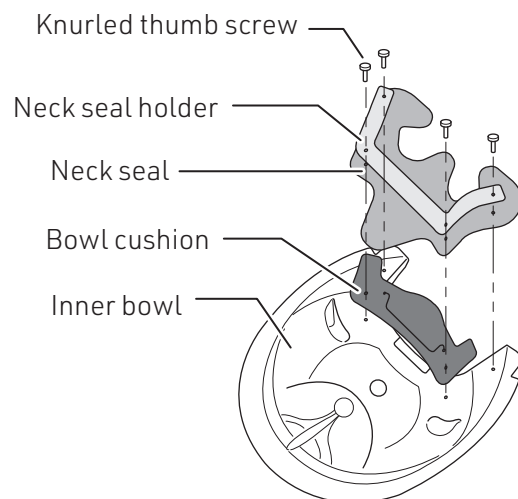

Disposal of the Product

When disposing of the product or replaced parts, waste should be processed appropriately according to current laws and regulations in your country.

Specifications

Model number:	AY-YHBYMS AY-YHBSSS	AY-YHBYMO AY-YHBSSO	AY-YHBYMS2 AY-YHBSSS2
Outer dimension:Refer	Refer to the Product Dimension Diagram [page 22]		
Environment of use:	Temperature: 10°C to 30°C Humidity: 90% or lower (without condensation)		
Transport/ storage environment:	Temperature: -20°C to 70°C Humidity: 95% or lower (without condensation)		
Amount of hot water supply required:	At least 8.6 L/min		
Weight:	2.4 kg		
Compatible products:	<ul style="list-style-type: none">• YUME• YUME SWING• YUME SUITE• YUME OASIS (full lie-flat posture only)• W SWING YUME (full lie-flat posture only)• YUME DX• YUME ESPOIR• YUME NOBLE		

Product Dimension Diagram

[Unit: mm]

Nozzle Arch

AY-YHBYMS

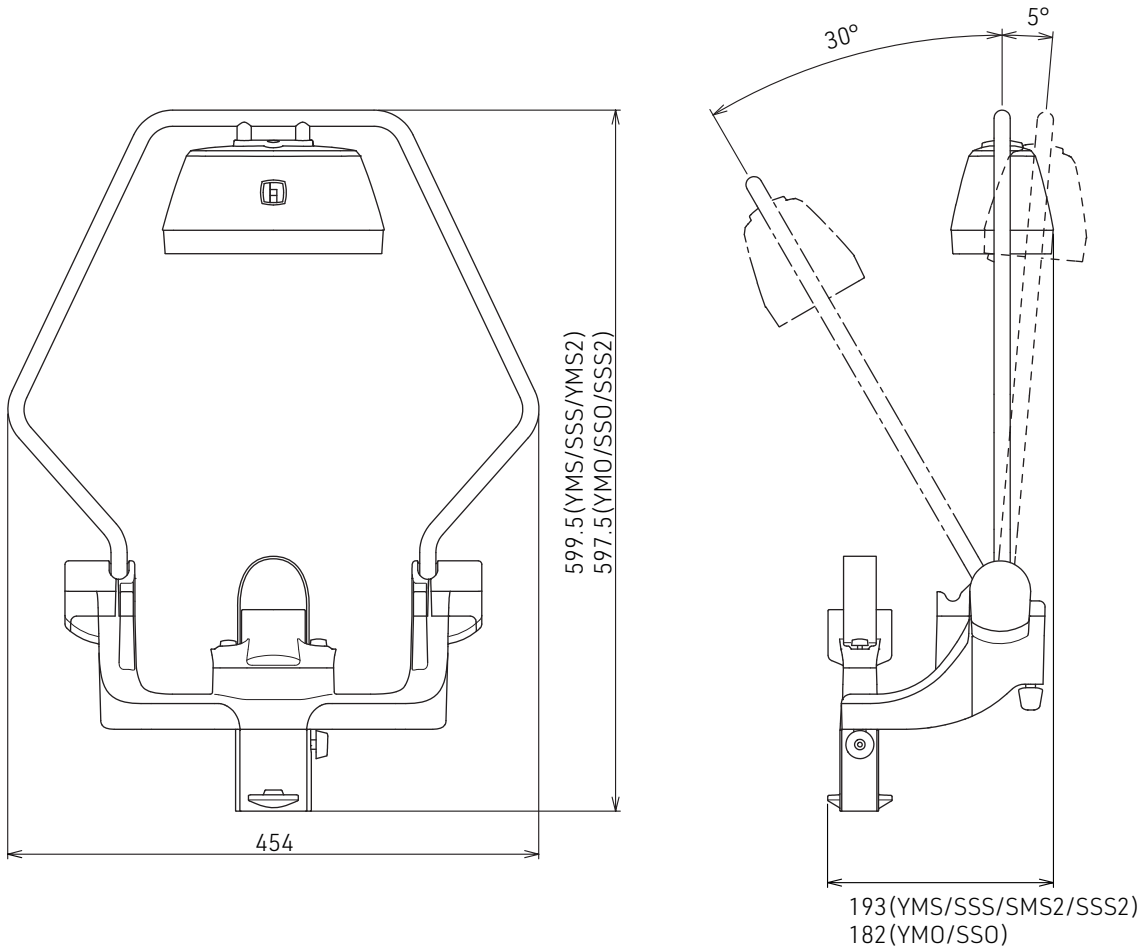

Inner Bowl

AY-YHBYM*

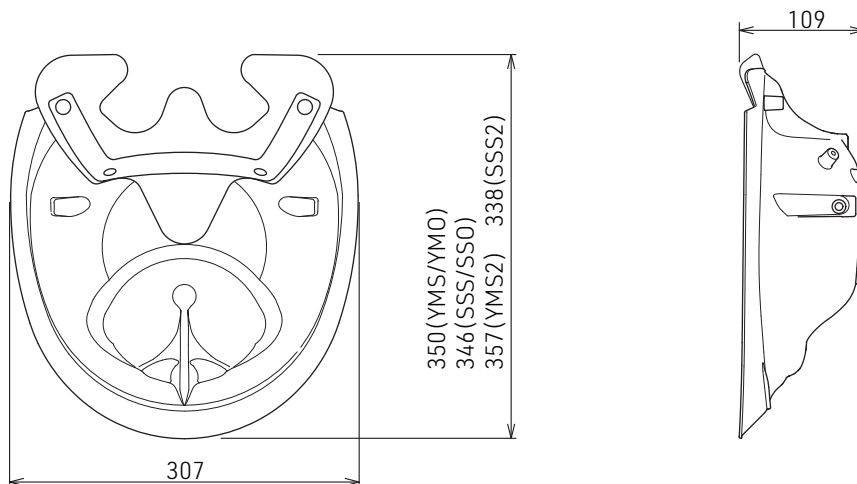

Notes



TAKARA BELMONT CORPORATION
1-1, 2-Chome, Higashi-shinsaibashi, Chuo-ku, Osaka, Japan
TEL : +81-6-6213-5945 FAX : +81-6-6212-3680

Printed in Japan