

RS SWING Installation Instructions

■ AY-P004~P011 / S033X

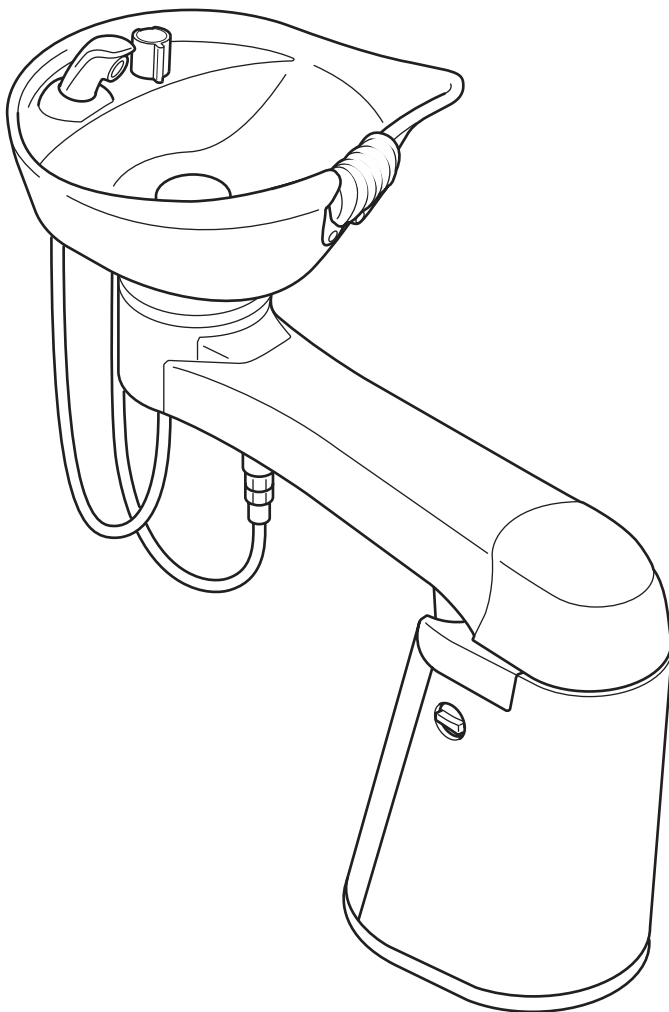

Contents

Before installation	2
Usage conditions	3
Content of packaging	4
Installation of Main Unit	5
Assembled	8
Overall Layout Diagram	12
Unit fixing position and Plumbing Layout	13
After installation	14

To the installer

- The instructions should be thoroughly read and understood before installation to ensure that RS SWING is installed correctly.
- After installation, give these instructions to the customer.

To the customers

- Customers must ask professional to install RS SWING.
 - Customers must not install RS SWING by themselves.
 - Customers must store these instructions in a safe place so as not to lose them.
- * The actual shape of RS SWING and the images and dimensions listed in these instructions may be modified and are subject to change without notice.

- The precautions listed here are to ensure that RS SWING can be installed safely, and to prevent any danger or risk to the person installing RS SWING or those around them. All of these precautions are important for safety. Takara Belmont is not responsible for any damage or risk to the person installing RS SWING or those around them due to accidents if RS SWING is installed without adhering to the precautions.



Caution

If RS SWING is installed after ignoring this symbol, "there is the risk of light or moderate injury or physical damage".

Before installation

■Floor surface

- Ensure that the material or finishing of the floor surface is waterproof or has a waterproof coating applied.
- This product weighs There are maximum 55kg. Please refer to the sufficient reinforcement work on the installation floor portion.
- Always ensure that the floor surface is horizontally level.
- Ensure that the floor surface is smooth and free from bumps around the attachment areas.
- Pipe risers

Hot water / water supply	Rc 1/2"; pipe risers from floor; rise dimensions: hot water 50 mm; water 50 mm
Drainage	VU40/VP40; pipe risers from floor; rise dimensions: 60 mm

- If the floor surface is tiled, cracks may occur when fastening the bolts during installation of the RS SWING main body. If this looks likely to happen, use the main body attachment diagram and template as a reference and change the material of the attachment area that is in contact with the floor to another such as plywood or mortar.
- The following levels of strength are required for the floor surface.

Wooden floor	Plywood thickness of 30 mm or more (two 15 mm sheets joined together)
Mortar floor	Mortar thickness of 50 mm or more
Special floor (stone finish)	A foundation with levels of strength listed above around the installation areas is required.

■Request measures to prevent water leakage under the floor and downstairs

- Be sure to take the necessary precautions to prepare for and prevent possible water leakage.
- Use waterproof flooring materials.
- When installing the product on the 2nd floor or higher, be sure to observe waterproofing (waterproofing works, installing a pan made of stainless panel, etc. or installing water leakage sensor.).
- Be sure to cover an opening of raised plumbing and a connection of pipes by caulking material, etc.

■Installation of pipes

The following are important points to adhere during the installation of pipes. Read through the details carefully and ensure that the pipes are installed correctly.

- This product is designed for indoor installation. Always install this product indoors.

■"Precautions during installation of pipes"

- Do not use pipes made of materials that may introduce rust for the water supply pipe. In general, VP pipes or other materials specified by regulations in that particular region, are recommended for installation.
- In general, Type L deoxidized copper pipes are recommended for hot water pipes.
- In general, the same diameter and same pressure is recommended for hot water pipes and water supply pipes.
- Always use a reamer to deburr the ends of cut pipes.
- Avoid using inverted U-shaped pipes (siphon) as these can cause air to become trapped.
- Always connect hot water and water supply pipes after removing all contaminants such as dirt, sand and oil. Failure to follow this instruction may cause problem.
- Ensure that the drain pipe is installed at a gradient of 1/50 for a diameter of $\phi 75$ or less, or 1/100 for a diameter of $\phi 75$ or more.
- Do not connect the hot water and water supply pipes in reverse. Connecting pipes in reverse will mean the temperature of water cannot be controlled properly by the water faucet, which can cause problems including burns.
- Ensure that the hot water pipe from boiler is only run over a short distance so as to minimize resistance. Longer pipe can cause fluctuations in temperature and poor hot water delivery.
- Boiler pipes
 - In general, the same diameter and same pressure is recommended for main hot water pipe and main water supply pipe.
 - Ask professional to install boiler.
- Product comes with hair catchers installed. Handle it with care.
- Always wrap pipes with lagging material after installation is complete.
- After connecting the pipes and executing water flow test, clean the filters and showerhead.

Usage conditions

■ Hot water supply and water supply conditions

Water used	<ul style="list-style-type: none">•Public water supply (do not use non-drinkable well water or water that contains rust or sand.)•If the water hardness is 80 ppm or higher, install a water softener to prevent the buildup of scale within the basin body. Aeration may be minimal when using shampoo even if drinkable well water is used, so a water softener should be installed.
Hot water supply, water supply pressure	<ul style="list-style-type: none">•Use a pressure between 0.1 and 0.4 MPa (1 to 4 kgf/cm²). If multiple RS SWING are used, ensure that the pressure does not drop below 0.1 MPa (1 kgf/cm²).•Set the water supply pressure \geq hot water supply pressure.•Set the difference between the hot water supply pressure and water supply pressure to within 0.2 MPa (2 kgf/cm²).
Hot water temperature into the product	<ul style="list-style-type: none">•Set the hot water temperature to 80°C or less.•Set the temperature 10°C or higher than the shower temperature used.
Water boiler	<ul style="list-style-type: none">•Do not use steam with the hot water supply.

Contents of Packaging

■ Basin



■ Base

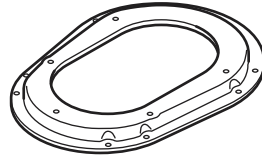

■ Rear cover

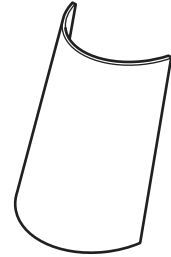

■ Main unit

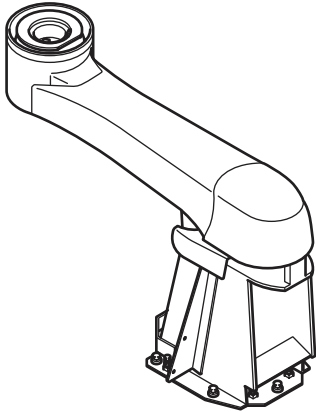

■ Base cover

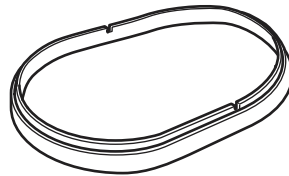

■ Front cover

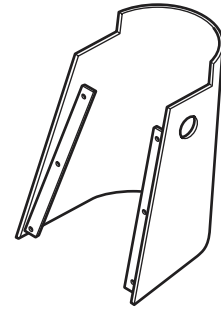

■ Stop valve knob



■ Plug



■ Neck cushion

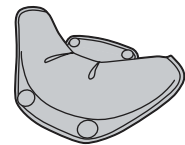

■ Stainless flexible pipe / Stop valve

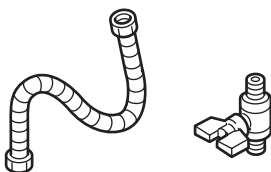

■ Drain cap / Hair catcher



■ Screw Set

■ Level adjustment plate

■ Operating manual

■ Installation manual (this manual)

Installation of Main Unit

●Opening of the packing

(1) Takes out the base.

●Marking the bolt anchor points

○Refer to the floor template (pages 14 to 15) and overall layout diagram, check the dimension of the raised pipes of water, hot water and drain, and prepare for the installation.

(1) Set the paper template on the floor aligning it with the floor fixing position of the fixing base.

*The floor fixing point of the fixing base differs depending on the chair used with Yume Swing.

(2) Mark the screw or bolt anchor position of the fixing base (four locations).

●Secure the fixing base on the floor using the screws or the anchor bolts.

Fix the base to the floor with four screws and washers.

- a) Plywood floor ; Hex head tapping screw M8-60
- b) Concrete floor ; Anchor bolt M8-70
- c) Tile floor ; Remove the tile with template paper.
Put the plywood and fix the shampoo unit to the floor.

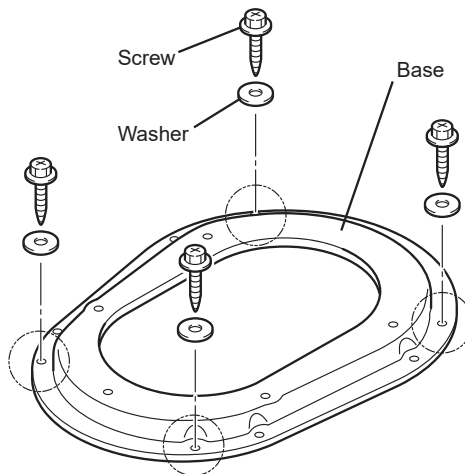

Caution

- To use a fixed position adjacent if you can not use the standard fixed position.
- To increase the fixed position when the strength of the floor can not be taken well.
- Since the cover and base of the interval is narrow, the floor finish up when the base.
- The depth of the pilot hole of the anchor bolt, the bolt head is set to be from the floor within 15mm.

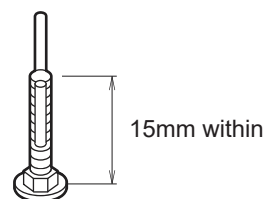

●Installation of Main unit

(1) Remove four screws from the base plate of shampoo unit and remove shampoo unit assembly from the pallet.

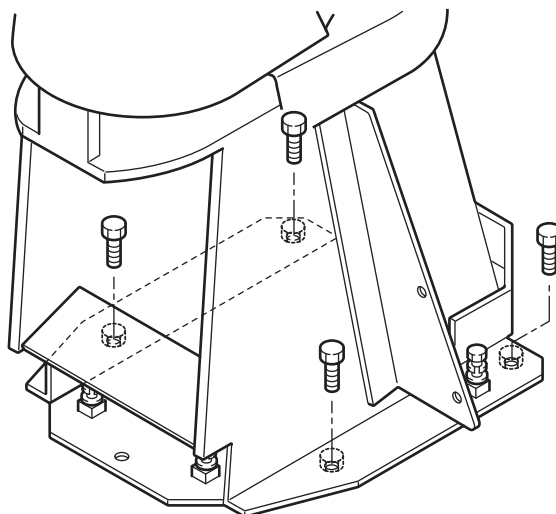

(2) Fix the shampoo unit to the base with five fixing screws, spring washers and flat washers.

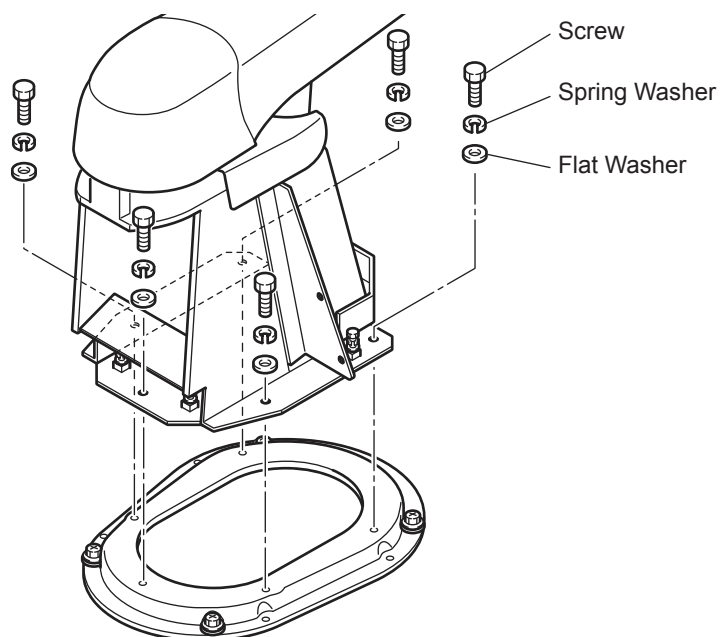

Bolt to be used : (M8 hexagonal head bolt (with washer) 5pcs.)

Caution

- Always have at least two people to do this process. It may cause breakage of the product or injury.
- Do not drag the Main unit while holding. The foot part of the basin is made of steel, so dragging it may damage the floor surface.

● **Height and horizontal adjustment.**

- (1) Using the level vial, adjust the level with four adjuster screws on the base plate.
* Height measure of Shampoo basin mounting surface is 676mm.

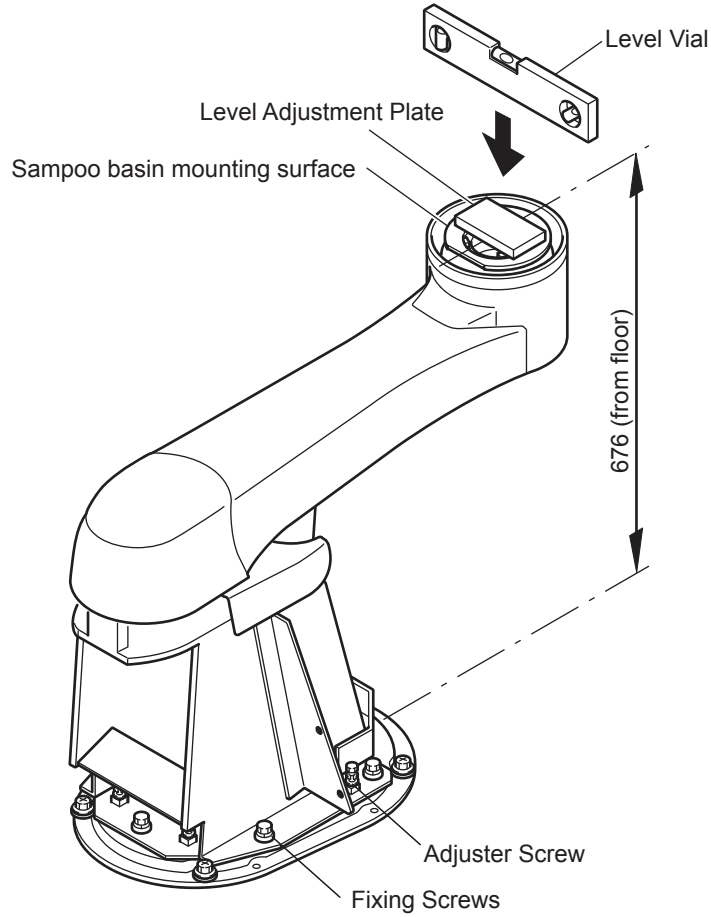

- (2) Fasten the Fixing Screw

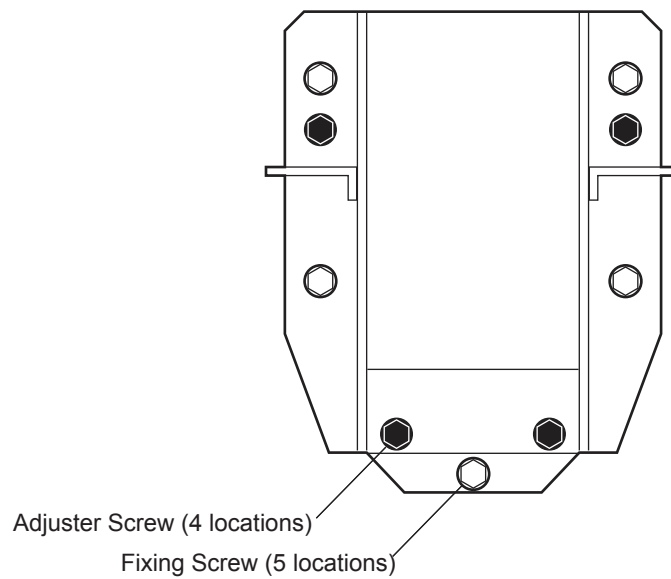

Assembled

●Set of base cover

Attach the base cover on the base.

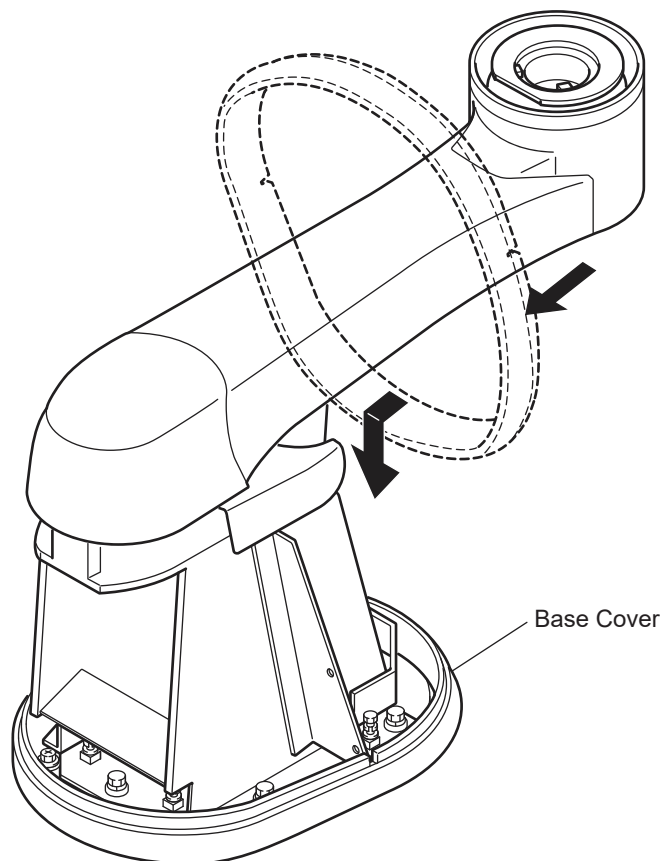

●Set of shampoo basin

Attach the shampoo basin to the top of the arm and fix it with a truss screw and a plug.

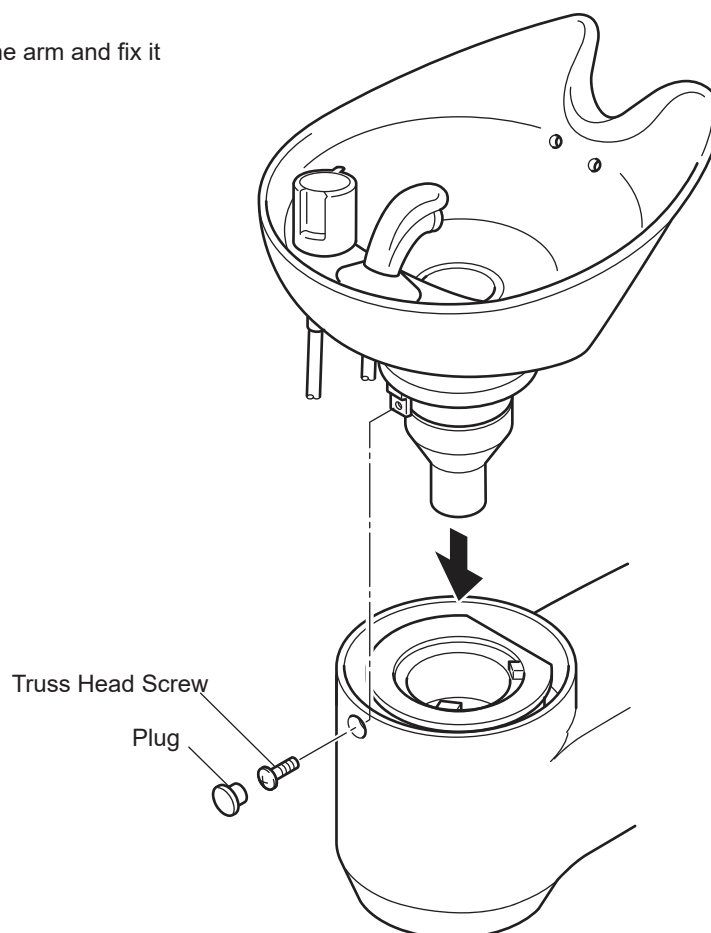

● Connection of the Water supply hose

Connect the water supply hose and drain hose.

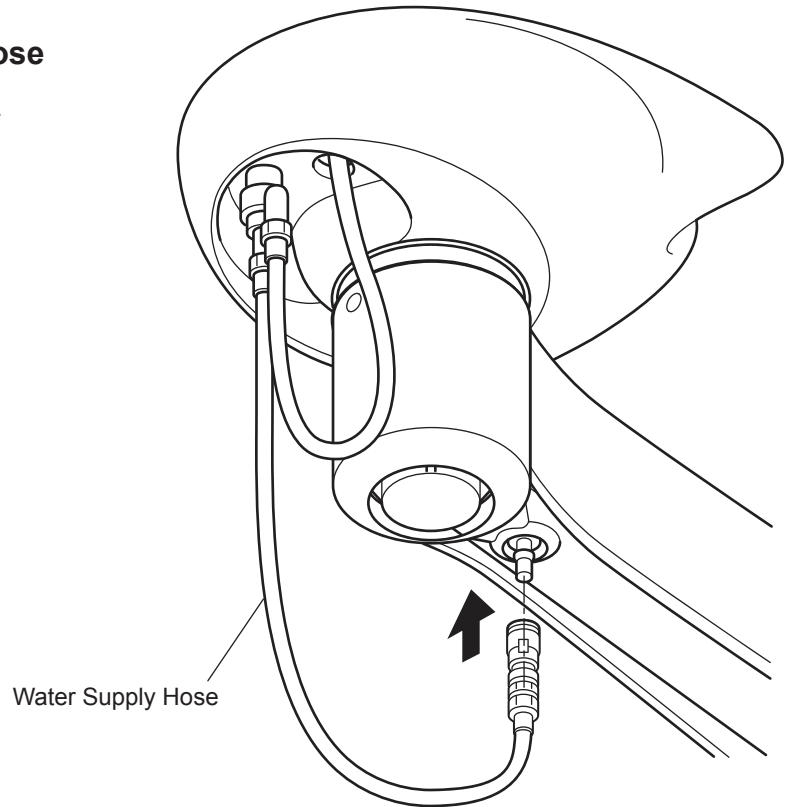

● Connection of the Drain hose

- ① Insert the drain hose with a bearing sleeve to the raising drain pipe.
- ② Press the bearing sleeve to the drain pipe and fit it into the drain pipe so that the drain hose and the drain pipe are connected tightly.

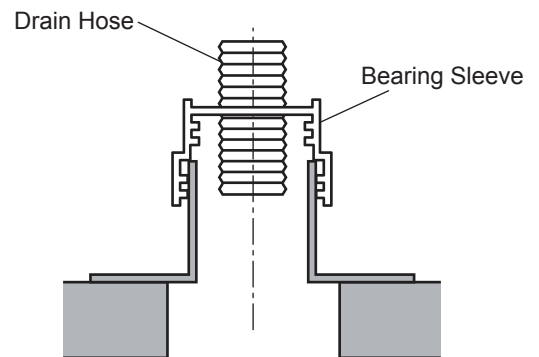
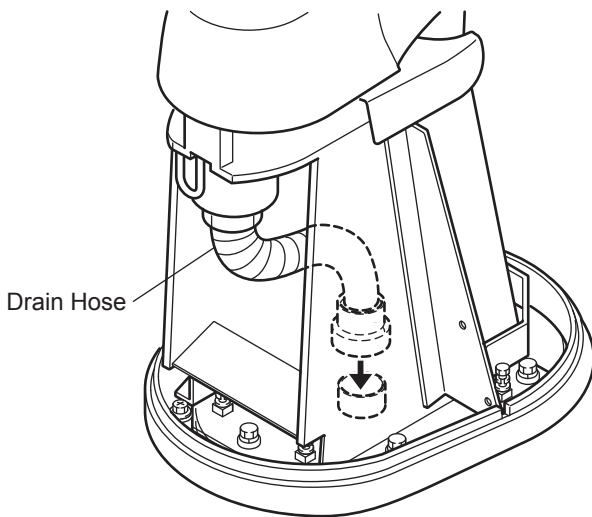

● VU50 Drain pipe

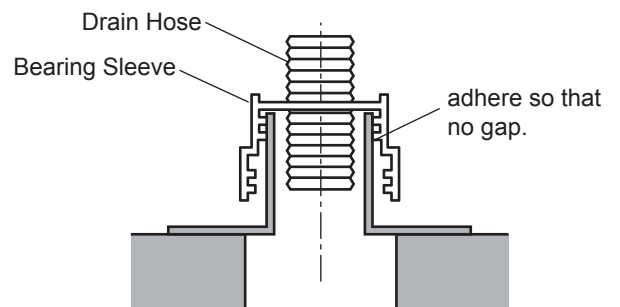

● VU40 Drain pipe



Caution

Please make sure of no double trap.
(The drain part of the basin is with trap.)
Double trap will cause bad water flow.

●Connection of the water supply pipe

* Before connecting the pipes, remove any waste from pipes, such as dust, dirt, sand, or oil.

- (1) Bend each stainless flexible pipe at suitable angle for connection.
- (2) Connect the water and hot water lines with stainless flexible pipes.

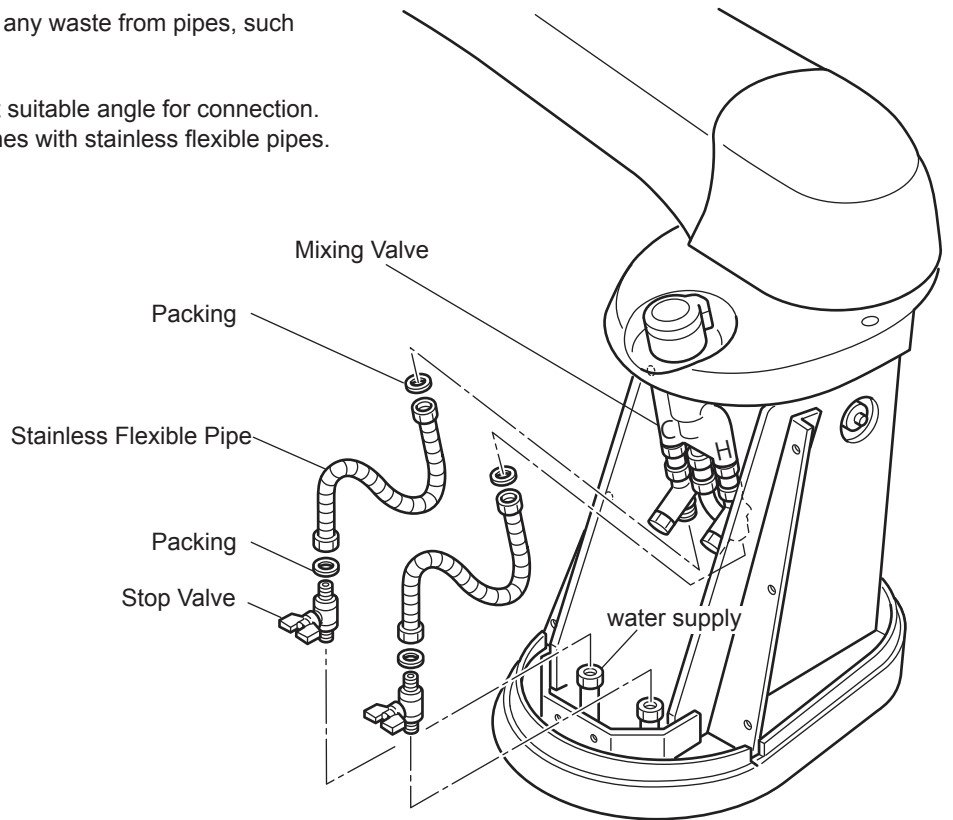

●Mounting of Stop valve knob

- (1) Fix the front cover to the shampoo unit body with six tapping screws.
- (2) Attach the stop valve knob.

Screw to be used : (4mm tapping screw, 6pcs.)

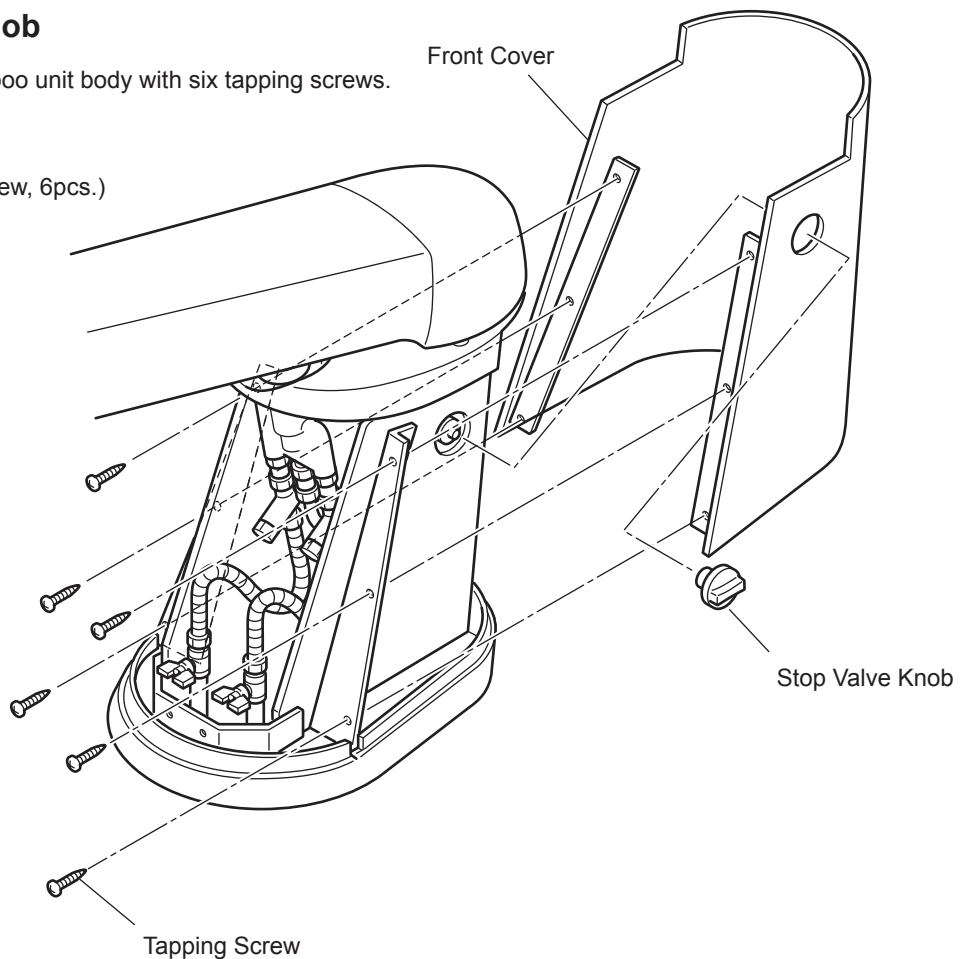

●Test water flow

Caution

Always test the water flow to prevent accidents during use.

* Test the water flow and inspect the following items. The hot water may be slightly tainted at the start of the water flow test, however this does not indicate any problem.

* For safety reasons, the product's thermostat is designed so that the hot water does not exceed 53°C.

(if the supply pressure is the same, water is 20°C and hot water is 60°C)

(1) Is there no water leaking from the pipe joints?

The pipe joints may come loose during transportation, so check the joints within the basin thoroughly.

(2) Are the hot water supply and water supply pressures at the same, stable pressure?

If the pressure is not the same, see "How to adjust faulty temperature regulation" below.

(3) Can temperature be controlled properly?

(4) Check that the shower outlet flow is sufficient, by the following as a guide for flow rate.

Shower outlet flow rate

Hot water supply pressure, water supply pressure:	0.1 MPa each
Shower outlet temperature	: 40°C

At 40°C : Approximately 8 L/min

— How to adjust faulty temperature regulation —

○Contents of defect

① Something wrong with hot water (Temperature is unstable)

② Hot water (high temperature) does not come out

③ Water (low temperature) does not come out

○Presumed cause

① There is difference in the water supply or hot-water supply pressure, or the pressure of hot water supply is higher than the pressure of water supply. the pressure of water supply \geq the pressure of hot water supply
[The difference should be in the range of 0.2MPa]

② Pressure of water supply and hot water supply is high

[These two should be in the range between 0.1 and 0.4MPa]

○How to react

Connect a pressure reducing valve (Optional) on the upper side (mixer side) of the filtered check valve, then adjust the pressure.

(It is recommended that water supply pressure and hot water supply pressure become the same pressure)

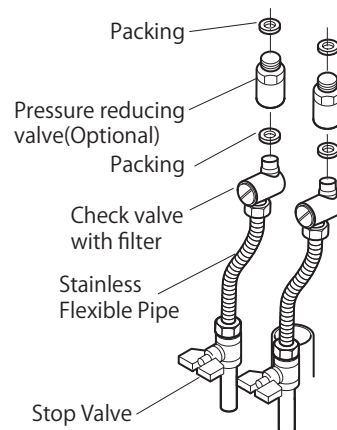

●Mounting of the rear cover

Attach the rear cover to shampoo body.

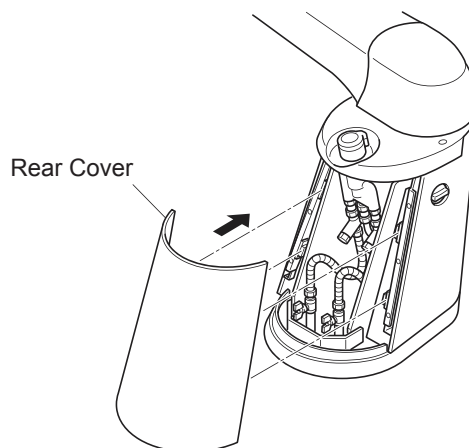

Dimensions

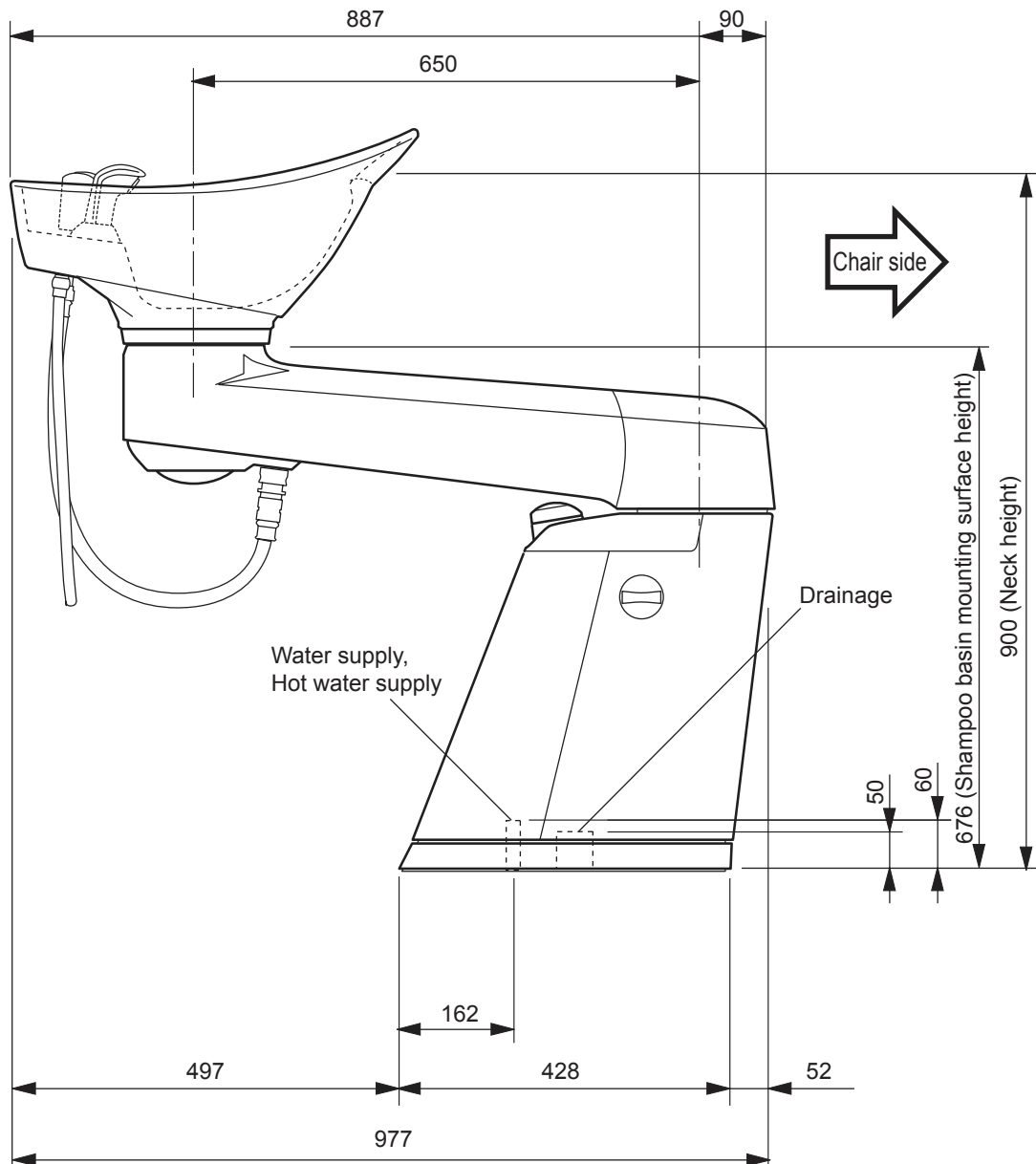
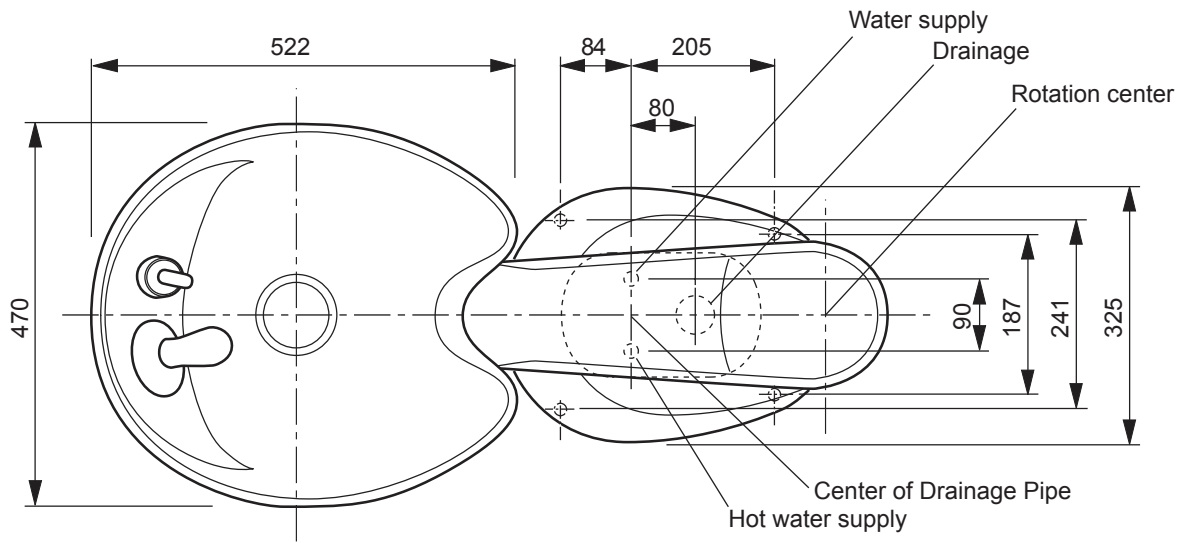

After installation

●Inspection

Inspect the following items.



Caution

Be sure to execute the inspection without fail to prevent accidents during operation.

- (1) Check that there are no missing screws or other parts.
- (2) Check that there are no loose parts on the shampoo unit .If any part of the shampoo unit is loose, check the bolts at the joints again.
- (3) Check that there are no cracks or contamination on the basin.
- (4) Check that there are no problems, such as flaws on the external appearance.
- (5) Check that there are no water leaks on the floor.

●Attach neck cushion on the basin

Execute the installation using the following procedures:

- (1) Set the neck cushion to the end of basin in the direction as shown in the image.



Caution

Be careful about the installation direction.
If the cushion is installed in the wrong direction, it may contact the backseat.

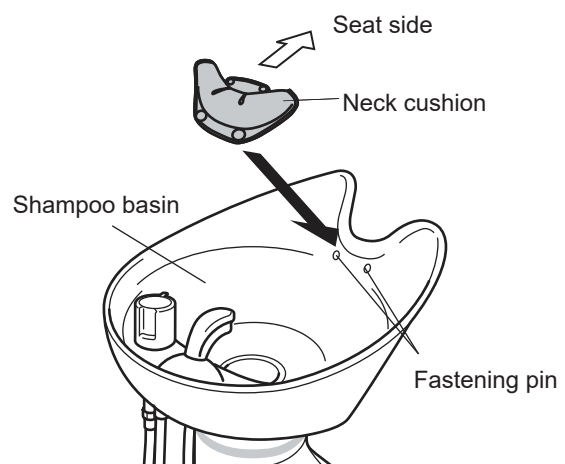

- (2) Attach the hooks of the neck cushion to the fastening pins inside of basin.



Caution

* Take care not to lose the fastening pins.

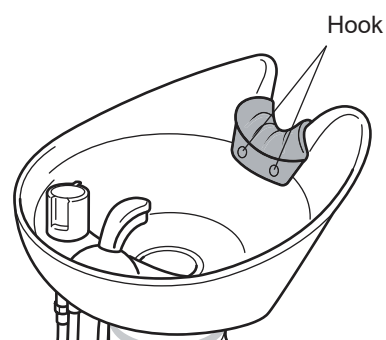

- (3) Adjust the shape of the neck cushion and attach the basin side hooks of the neck cushion to the fastening pins outside of basin.

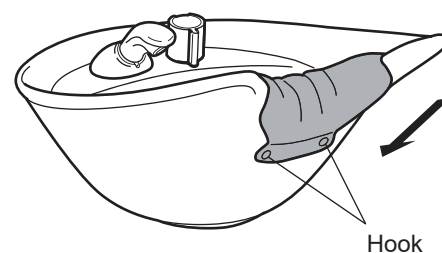

Unit fixing position and Plumbing Layout

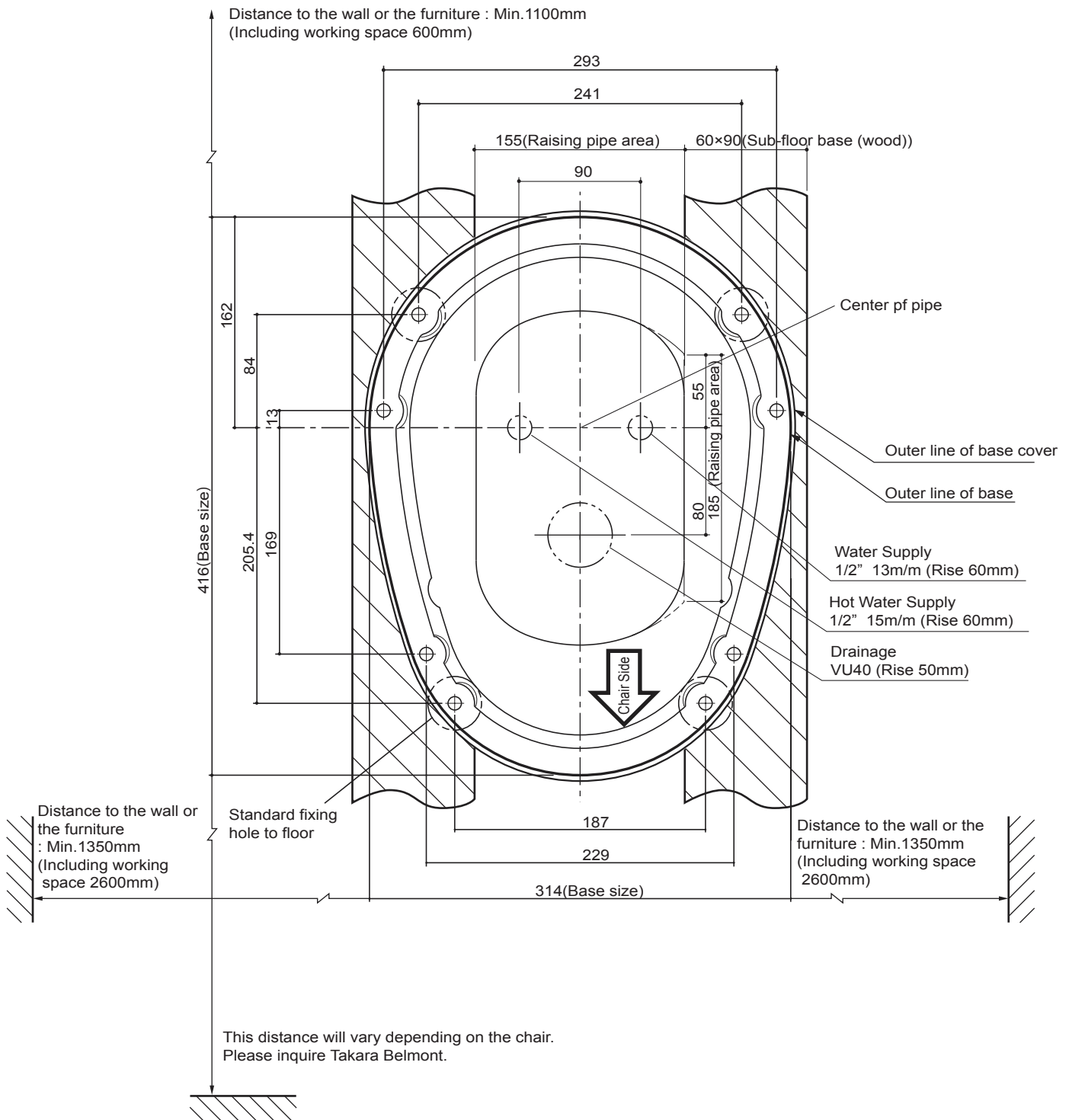

● Fixing the base to floor.

- *The holes marked are the standard fixing holes to floor. Please ensure to fix the base to floor at 4 points. (Anchor bolt M8-70 (4pcs.) or Hex head tapping screw M8-60 (4pcs.)).
- *If the standard fixing holes cannot be used, please use the spare holes nearby.
- *If in case the floor is not strong enough or enough strength cannot be secured, please increase the numbers of fixing bolts/screws to be used.

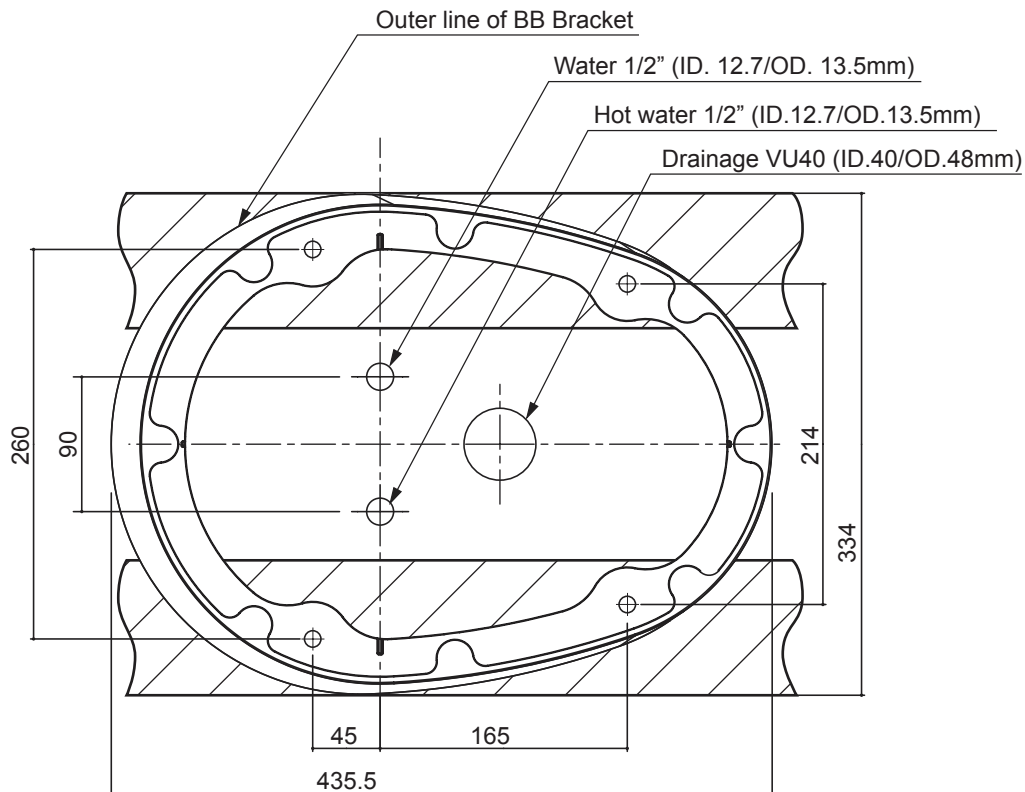

● Fixing the BB Bracket to floor.

*If a BB Bracket will be used, the fixing points to floor will differ from P.14. (The sub-floor base measurement is the same). Please refer the above diagram when installing BB Bracket.

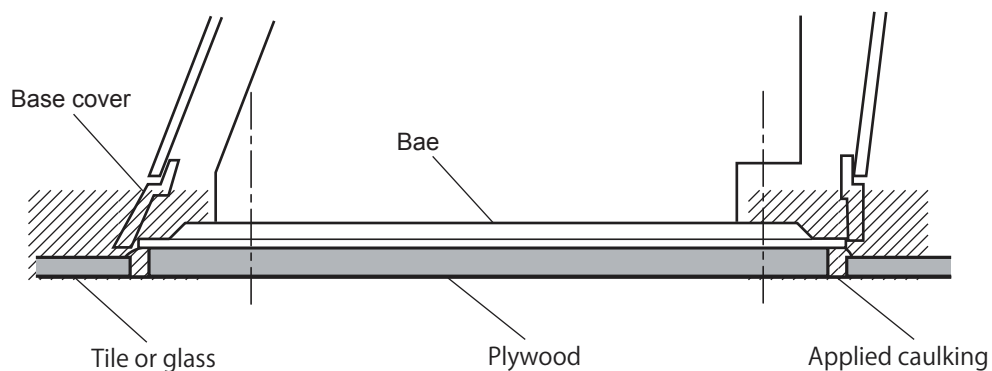

●Floor Surface of Tile or Glass Finish

The tiles or glass of the floor surface will break when the bolts are embedded during installation of the shampoo unit. If this is the case, the installation area should be finished with materials such as plywood or mortar.

- (1) Peel off the inner tiles or glass along the outside lines of the installation area of the floor. The work must be done carefully; otherwise, the peeled portion may be obvious.
- (2) Place composite panels in the peeled-off area. The panel surface should be higher than the surrounding tile or glass surface (within 2 or 3 mm).
- (3) Caulk gaps between the composite panels and the finished surface.

NOTE



TAKARA BELMONT CORPORATION

1-1, 2-Chome, Higashi-shinsaibashi, Chuo-ku, Osaka, Japan

TEL : (06) 6213-5945

FAX : (06) 6212-3680

Printed in Japan

1E0512A0