

MAJOLICA PORTO

Operating Instructions

MAJOLICA PORTO

○Basin

EX-SB 1* [single tap type]

EX-SB 2* [double tap type]

○Plumbing and fittings kit

AY-SB P1 [P trap / single tap type]

AY-SB P2 [P trap / double tap type]

AY-SB S1 [S trap / single tap type]

AY-SB S2 [S trap / double tap type]

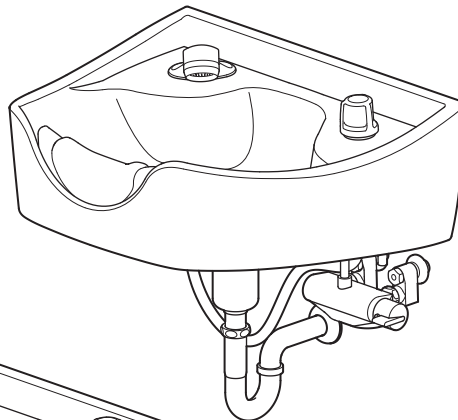

(Above drawing is EX-SB 1*/AY-SB P1)

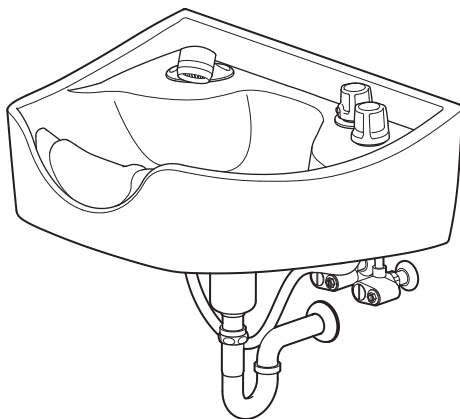

(Above drawing is EX-SB 2*/AY-SB P2)

Thank you for purchasing this Takara Belmont product.

The instructions contained in this booklet should be thoroughly read and understood before use.

Using this product before reading this operating instructions may result in an accident.

This product is an industrial shampoo unit designed for barbers and hair salons. Only use this product for its intended purpose and do not use it for non-hairdressing work.

Keep this instruction and refer back to them when required.

For installation and assembly of this product, contact your local Takara Belmont dealer.

Table of Contents

General Safety Instructions	2
Safety Precautions	3
Precautions for Use	5
Precautions for Use of Basin Products	7
Precautions on Resin (Plated) Parts	7
Position of Warning Label	7
Before Using	7
Name of Each Parts	8
Accessories	8
Preparations	9
How to Use	10
Guiding Customers	14
Maintenance	16
Daily Inspections	20
Standard Duration of Use	20
Before Requesting Repairs	20
Consumables	21
Disposing of this Product	21
After-sales Service	21
Specifications	22
Product Dimensions	23
Daily Check Guide	24

General Safety Instructions

■ Before Using

The "Safety Precautions", "Precautions for Use", "Precautions for Use of Basin Products" or "Precautions for Use of Resin-plated Parts" contained in this booklet should be thoroughly read and understood before use.

■ Precautions Listed Here

This instruction manual contains important information to avoid personal injuries, or property damages against you or your clients by using this product correctly.

These precautions are important for ensuring safety.

Adhere to these precautions at all times.







TAKARA BELMONT is not responsible for any damage or risk to the person using this product or those around them due to accidents if this product is used without adhering to the "Safety Precautions", "Precautions for Use", "Precautions for Use of Basin Products" or "Precautions for Use of Resin-plated Parts".

In this case, the person failing to adhere to the "Safety Precautions", "Precautions for Use", "Precautions for Use of Basin Products" or "Precautions for Use of Resin-plated Parts" will be responsible for any damage or risk incurred.

Detailed descriptions of symbols are provided below.

Read and understand these symbols thoroughly before reading this Operating Instructions.

■ Symbols

 WARNING	This mark warns the user that "improper use may cause death or severe personal injuries".
 CAUTION	If this symbol is ignored and the product is used, "there is the risk of death or serious injury to the user".
Note	Description of "ideal points to adhere to for safety".
 Common danger, warning and caution notifications	 Indicates what a user is forced or instructed to do.
 This mark indicates that the user must be ALERT against a possible danger.	 Indicates the notice of high-temperature condition.
 Do NOT Disassemble	

Safety Precautions



WARNING



Install on a stable area.

Fix the basin vertically on a flat wall.
After installation, check that the basin is securely fixed.
Failure to follow this instruction may cause the basin come off the wall, and crack the basin or be injury.

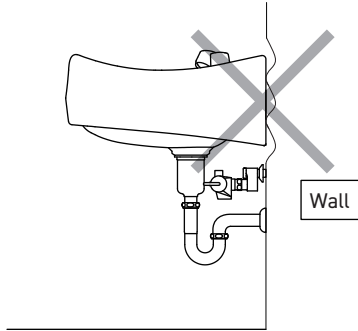

Adjust the temperature of warm water while checking it by hand.

When adjusting the hot water temperature, reduce the volume of hot water, point the shower head away from the customer and check the temperature by your hand.
Take care when doing so, as hot water may come out of the shower head.



Do NOT lean against the basin.

If you provide any service for the customer leaning against the basin, the product may fall down and cause damage to the product or personal injury.



Do NOT Disassemble

Do NOT attempt to repair the unit by yourself.

Do NOT attempt to disassemble or repair the equipment on your own. Never attempt to modify the unit. It may fall or operate incorrectly, leading to injury.

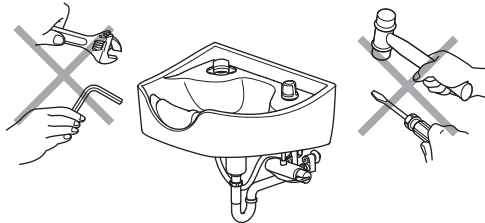

Do NOT get on or hang from the basin.

Do NOT attempt to disassemble or repair the equipment on your own.
Damage to the product or deformation may be caused. The basin could fall off the wall and break, leading to an injury.

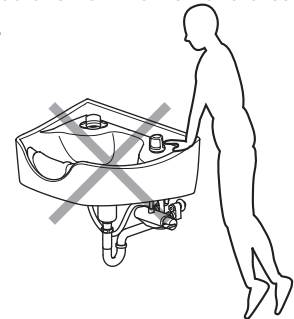

Return the tap to an appropriate position after using hot water.

- Return the tap to an appropriate position after using hot water. Continuing to use the hot water with the tap in the hot position may cause burns.
- Using other equipment that shares the same water/hot water supply source at the same time may cause unstable water temperature.



Do NOT use hot water (boiling water) of 60°C or higher.

Using hot water at 60°C or higher may deform or damage the ceramic basin, the shower head, or the tap, the neck cushion, the neck base, the neck fittings, the drain cap, the hair catcher, the drain housing.



CAUTION



Do NOT use for any other services, besides barber and beauty services.

This product is for barber and beauty professional use only. Do NOT use for any other services besides barber and beauty services.



Do NOT use outdoors.

This product is intended for indoor use only. Do NOT place outdoors or in vehicles. Be sure to use inside barber and beauty salons. Otherwise, the product may become damaged or break.



Do NOT use the product at temperatures below 0°C.

The parts may be damaged, leading to water leaks. If there is a risk of freezing, turn on the heater to keep the room temperature above 0°C.



Do NOT spurt out water with the shower head placed in the shower head holder.

Failure to follow this instruction may cause water to spill out of the basin, covering the customer with water. When supplying water with the shower head placed in the shower head holder, check the surroundings and then slowly turn the tap.



Do NOT drink the water.

This product is for the purpose of shampooing. Do not drink the water. The water quality may cause diarrhea or stomach pain.



Do NOT use with the plating peeled off.

If the plating on the tap or thermostatic control is peeling off, immediately stop using the product and contact your local Takara Belmont dealer for assistance. Continued use may cause injuries.



Do NOT bump, knock or hit the product.

Failure to follow this instruction may damage the product.

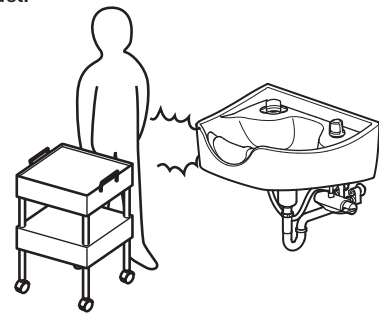

Before use, ensure the shower head faces down.

- When turning the tap on or off, be careful so water does not splash. If you do, immediately wipe up the water.
- Be careful not to spill water on the floor. If you do, immediately wipe up the water. Otherwise, the floor may be damaged and leak.

Precautions for Use

CAUTION

Do NOT use a cleaning agent of strong acid/strong alkali.

When cleaning drainpipes etc., do NOT use a cleaning agent that contains caustic soda (NaOH) or caustic potash (KOH) as its principal component.

Never pour thinners, alcohol, nail polish remover, gasoline or kerosene into the drain.

Failure to follow this instruction may damage the drainpipes.

Do NOT use chemicals other than neutral detergent or add heat.

Failure to follow this instruction may cause discolouration or alteration.

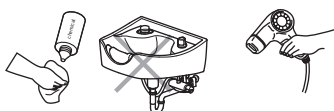

For sidewash only

This product is shampoo equipment intended for side shampooing.

Do NOT use the product for frontwash.

Water may overflow from the basin during shampooing, it may fall to the floor and deteriorate.



* Figure shows frontwash

Do NOT leave the shower head in the filled water basin.

Failure to follow this instruction can result in a back flow of water in the basin when the pressure in the water piping decreases as the water supply is suspended for execution of work.

Wipe any chemical substances off the product immediately.

Immediately wipe any chemicals, such as hair dye, off the neck cushion and basin. Otherwise, discolouration, deterioration or deformation may result.

Do NOT use a chemical agent or hot water. Failure to follow this instruction may cause deterioration/discolouration.

If chemicals spatter on the floor or come into contact with the unit, immediately wipe them off.

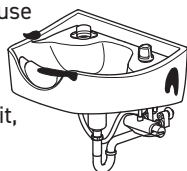

Clean the hair catcher regularly.

Clean the hair catcher as regularly as possible.

If it is used without cleaning, the drain port is clogged with a buildup of hair etc., which causes water to overflow, resulting in unsanitary conditions.

Try to clean it every time you shampoo customer's hair.

After the completion of work, do NOT leave the upper and floor units connected.

In the event of water leakage from cold/hot water supply couplers, water leak accidents may occur.

Fully close the tap.

After the completion of use or work, fully turn the tap clockwise to the end to ensure that the water stops.

Failure to completely stop the water may cause water leak accidents.

If not in use, do NOT block the drain port.

After the completion of work, do NOT block the drain port with the trap cap, a towel, or a shampoo cloth.

If warm water comes out by mistake or a small amount of warm water comes out due to an increase in water pressure late at night, water may spill out of the basin, resulting in a water leak accident.

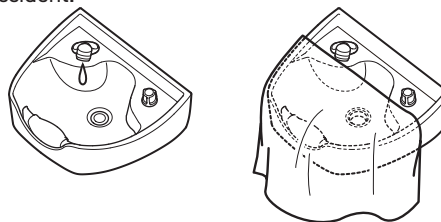

Avoid exposure to direct sunlight and excessive heat.

Failure to follow this instruction may cause discolouration and deterioration of resin parts.

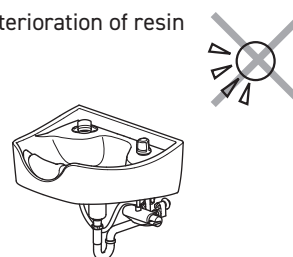



CAUTION



After use, be sure to wipe any wet surfaces around the basin.

If the product is left with moisture, it may cause a malfunction of the equipment or make it impossible to remove soil.



Do NOT drop or place any heavy or sharp objects on the basin.

Failure to follow this instruction may cause damage such as scratches or cracks to the basin.



Ensure that the supply of hot water is kept at 80°C or less.

Failure to follow this instruction may cause a malfunction in or damage to the stop valve, check valve, flexible hose, thermostat tap, etc.



Keep heavy or sharp objects away from the product.

Damage or breakage may result.



Do NOT use a scourer.

Do NOT use a scourer to clean the basin, the tap, the shower head or the shower head holder. Using hard cleaning tools such as a scourer or a sponge with a scourer, metallic scouring pad or nylon scouring pad may cause scratches.



Do NOT bump any hard objects against the tap of the resin-plated parts.

Failure to follow this instruction may cause scratches or cracks on the plated surfaces and peeling of plating, resulting in injury.



If the floor is wet, be sure to wipe it up as it could cause injuries.

If the floor is wet after a shampoo, immediately wipe it up.
Failure to follow this instruction may degrade the floor or you may slip and fall.



Do NOT touch the hot water supply pipe or mixing pipe.

The hot water supply pipe or mixing pipe may become very hot. Do NOT touch the pipes directly.



Take care in handling the neck cushion.

Do NOT bring cutters and sharp objects, such as scissors, (including grown nails) into contact with or press them against the neck cushion.



Do NOT drench the shower head holder with water.

Do NOT wet the shower head holder with water. Failure to follow this instruction may cause water leaks.

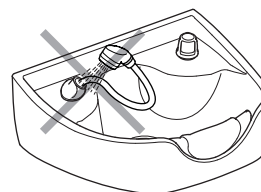

Return the shower head to its holder with the shower head plate facing the basin.

Failure to follow this instruction may cause water to spill out of the basin or splash on the customer with water.



Clean the shower hose.

Clean the shower hose as regularly as possible. Continuing to use the shower hose without cleaning, it may cause that the dirt of the shower hose will not come out.



Take care when handling the shower hose.

Do NOT pull the shower hose too hard or beyond its reach. It may become damaged and leak.



Do NOT use aroma oil.

The oil may cause damage to resin parts, such as the shower head, shower head holder, shower hose, tap, neck cushion, neck base, neck fittings, hair catcher, and trap cover.



Keep hard objects away from the drain trap and the P (S) trap.

Avoid any impact on the traps.

Precautions for Use of Basin Products

The basin is made of porcelain.

Note in advance that bends and deformations cannot be avoided depending on the product in molding of the neck position and the porcelain, and there are slight variations in height, shape, and weight.

In addition, because of the nature of porcelain, pouring hot water in a porcelain part may result in a sudden expansion of that part, causing cracks in the surface.

Do NOT pour hot water in the porcelain. Failure to follow this instruction may damage to the porcelain, causing injury, or cause water to enter the upper unit due to a water leak, resulting in formation of rust.

Precautions on Resin (Plated) Parts

- Resin plating is adopted for part of the tap and the thermostatic control.
 - Plating is a thin, hard metal film applied to the surface that may crack or peel due to corrosion or aged deterioration.
 - Scratches or cracks may occur on the plated surface due to impacts from falling objects or when a hard object hits the surface.
 - Peeling of the plating may occur from scratches or cracks on the plated surface.

 CAUTION	Check that there are no scratches, cracks, or peeling of the plated surface of the taps before using the product. If peeling is observed, immediately stop using the product and contact your local Takara Belmont dealer. Continued operation may result in injuries.
---	--

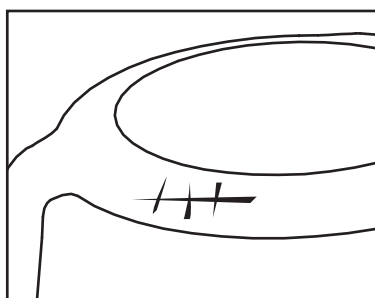

Example of scratches on the plated surface

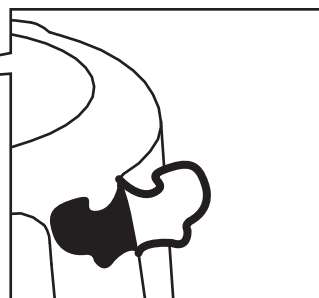

Example of peeling of the plated surface

Position of Warning Label

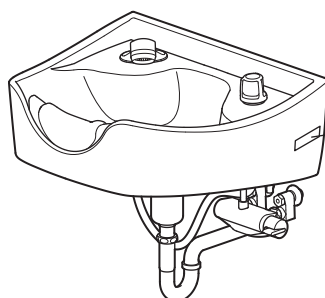

 注意 CAUTION	 注意 CAUTION	 注意 CAUTION
		
60℃以上のお湯を使わない 火傷や器具破損の恐れあり Scalding and product damage risks Avoid water 60℃/140°F or hotter.	ヘアダイ（毛染剤）は、すみやかに洗い流す 長時間置くと変色、変質の恐れあり Basin discolouration and deterioration risks Wash any hair dye away immediately.	排水管部の洗浄は、苛性ソーダ、苛性力りを主成分とする洗浄薬は使わない。器具の劣化、破損の恐れあり Product damage and deterioration risks Do NOT use any caustic /erosive cleaners.
上記以外の注意事項については取扱説明書をよくお読みください。 Also observe the other cautions in the Operating Instructions.		

Before Using

- This product is shampoo equipment intended for side shampoo services.
Do not perform any treatment other than side shampoo.
- Check that all accessories have been attached properly.

*Side shampoo : This means that staff provide shampoo services standing next to the basin (in the side position.)

Name of Each Parts

Unit

< SINGLE TAP TYPE >

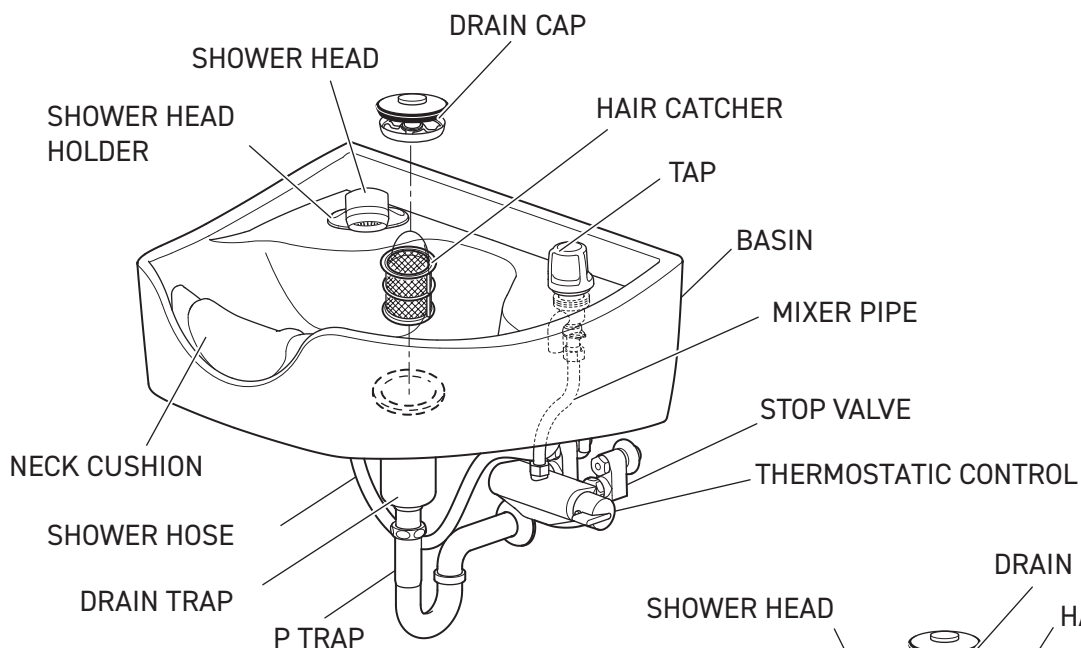

< DOUBLE TAP TYPE >

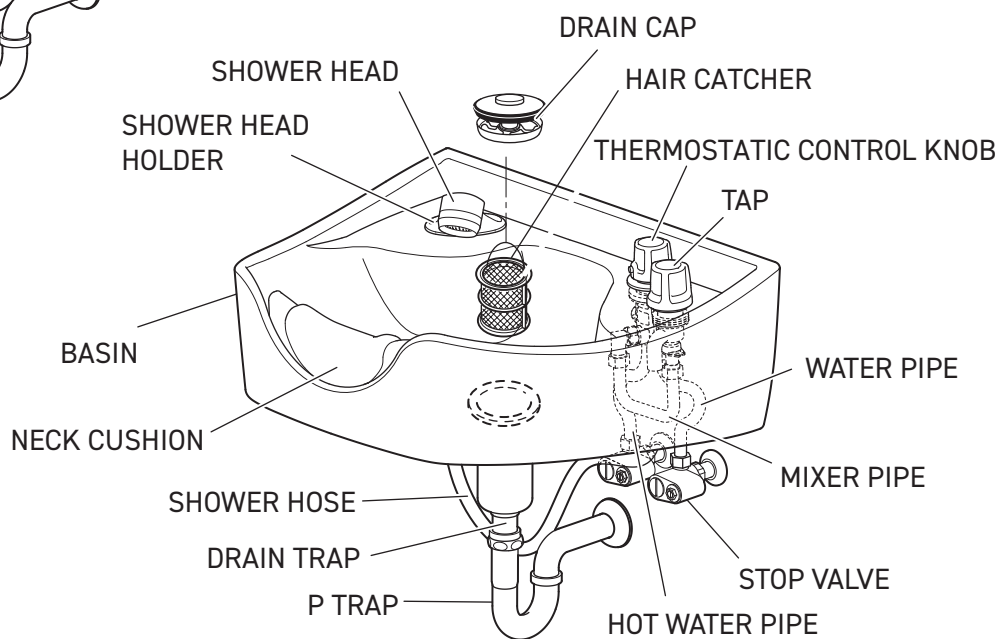

Accessories

□ Hair catcher...1



□ Neck fittings...1



□ Neck cushion...1

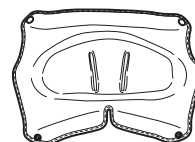

□ Drain cap...1

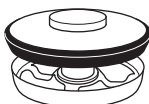

□ Wrench...1

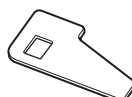

Preparations

■ Attaching the neck cushion

1. Check the proper direction of the neck cushion and the neck fittings.

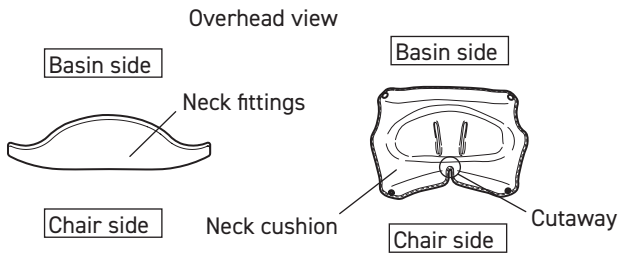

2. Hold the neck cushion, and fit it to the centre of neck fittings.

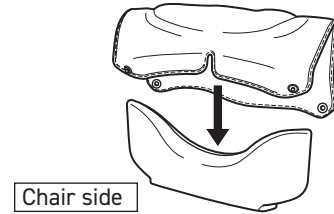

3. Adjust the height of neckrest fittings and right and left edges of neck cushion. (both sides)

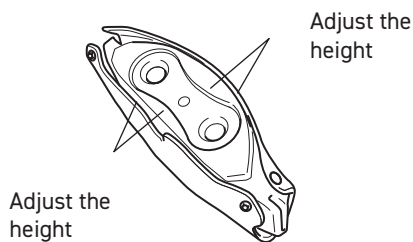

4. While pulling the neck cushion, secure it with the snap buttons (2 locations). As shown in the below illustration, secure the snap buttons at the bottom of neck fittings.

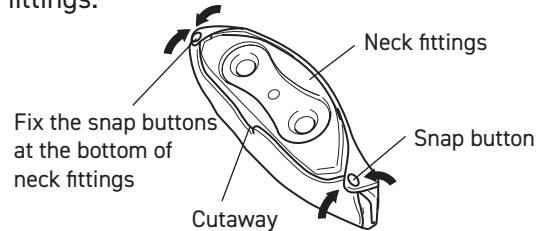

5. Insert and secure the neck fittings to the neck base. Pay attention to the proper direction of neck fittings. The surface of neck cushion with cutaway to be faced to the **chair side.**

* This side with cutaway should come to the chair side.

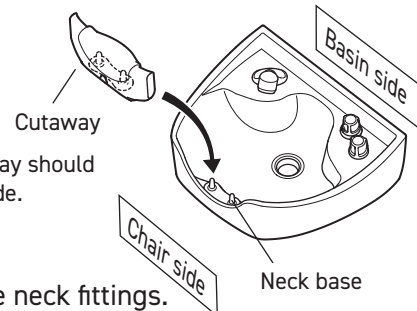

■ Removing the neck cushion

1. Remove the neck cushion from the neck base.

2. Detach the two snap buttons and remove the neck cushion from the neck fittings.



Do not force the neck cushion if it does not fit smoothly.
Instead, check the following points.
Forcing the neck fittings on may cause damage to the neck base or injury to customers.

- Check the neck fittings insert the direction.
- If the neck cushion is loose, check the direction of the neck cushion toward the neck fittings.
- If the neck fittings dowel hole is clogged with dirt, clean and remove the dirt before use.

If neither of the above are appropriate and the cause still remains unknown, contact your local Takara Belmont dealer.



When removing the neck cushion, remove the neck cushion from the neck fittings, and then remove the two snap buttons.
Applying excessive force to remove the neck cushion may damage the parts.

Note

The neck cushion is a consumable supply.
Replace them if they are extremely dirty or the surface has deteriorated, replace it (on a chargeable basis).

How to Use

■ Using the Shower head

1. Hold the shower head and pull it out.

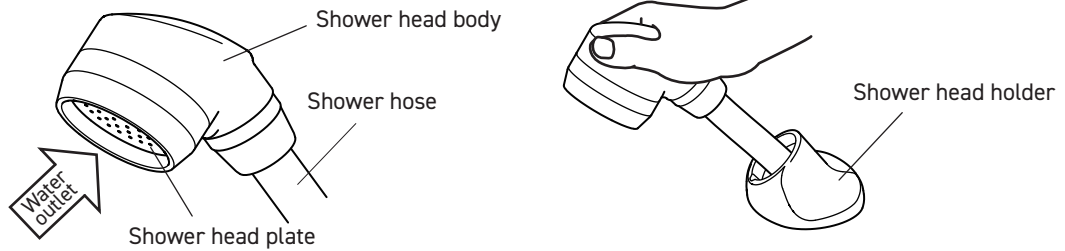

2. After using the shower head, be sure to put it back in the shower head receptacle.

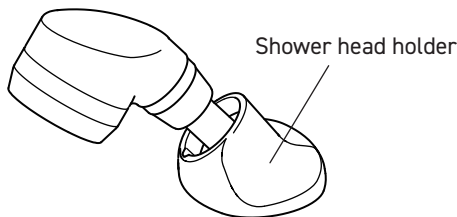

- Do not discharge a strong water stream when the shower head is in the shower head holder. Failure to take this precaution may result in system failure due to spilled water or damage to the floor.
- After using the shower head, be sure to put it back in the shower head holder. Failure to take this precaution may result in system failure due to spilled water or damage to the floor.

■ Output/Stop the warm water

1. Pull the shower head out to prevent hot water from splashing on the customer.
2. Turn the tap counterclockwise.
3. Warm water comes out from the shower head.
4. Turn the tap clockwise.
5. The warm water stops.

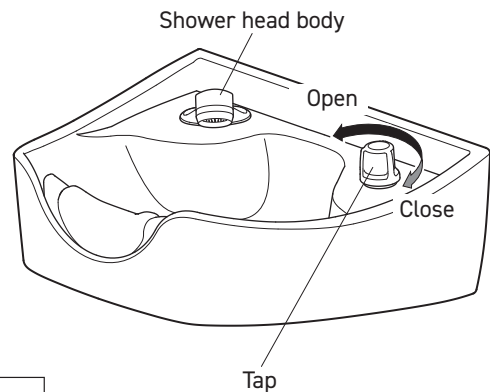

- After the completion of use or work, fully turn the tap clockwise to the end to ensure that the water stops. Failure to completely stop the water may cause water leak accidents.

Note

After stopping the water from the shower head, warm water may drip from the shower head for a while. This is a phenomenon in which residual water inside the shower head is discharged, and it is not a malfunction of the device. However, if it does not stop for several minutes, check that the tap is completely closed.



- When turning the tap, keep your rings and watch away from it. Contact with metallic objects may scratch or crack its resin-plated surface, causing the plating to peel.
- Before using the product, check that there are no scratches, cracks, or peeling of the plated surface of the tap. If the plating is peeled off, immediately stop using the product and contact your local Takara Belmont dealer. Continued operation may result in personal injury.



- Move the tap slowly.
- A quick turn of the tap may cause a noise or an abrupt change in water temperature.
- When you run hot water, be sure to hold the shower head with the shower head plate facing down.
- Be sure to check the temperature of the water before applying it to customer's head.
- After shampooing, do not cover the drain with the drain cap, towel or shampoo cloth as hot water may come out. Hot water that is accidentally trickle due to an increase in water pressure at night. This may cause water to spill from the basin, leading to water leakage.
- Do NOT use water 60°C or hotter. The basin, shower head, shower head holder, shower hose, tap, thermostatic control, neck cushion, neck base, neck core, hair catcher, trap cap, drain cap, drain trap may be deformed or damaged.
- If the drainage become sluggish, the drainpipe may be clogged with dirt. Discontinue use and contact with your local Takara Belmont dealer.

■ Adjusting the volume of water

1. Turning the tap anti-clockwise increases water flow.
Turning the tap anti-clockwise as far as it goes maximises the flow.
2. Turning the tap clockwise decreases water flow.
Turning the tap clockwise as far as it goes stops the flow.

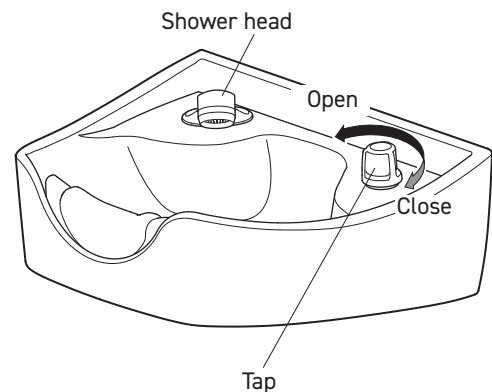

Note

- You may hear a noise inside the product, depending on its operating environment and conditions, but this is not a product fault. Pipes may make such a noise when water flows through them at a high pressure and flow rate. The noise can be reduced by controlling the water pressure.
- The tap may become stiffer when turned depending on the environment or condition that it is used in. This is due to deterioration of gasket of movable parts or a lack of grease as a result of aging. Replacement of the gasket or other parts, or a re-coating of grease is required.

■ Adjusting the water temperature

1 Turn the thermostatic control in the H or C direction to set the temperature to an appropriate level.

2 To use hot water turn the thermostatic control in the H direction while holding down the stop button.

* For safety reasons, this product is designed so that hot water of approximately 53°C or higher is not output.

(Conditions: At the same supply pressure, normal water temperature is 20°C and hot water temperature is 60°C)

< SINGLE TAP TYPE >

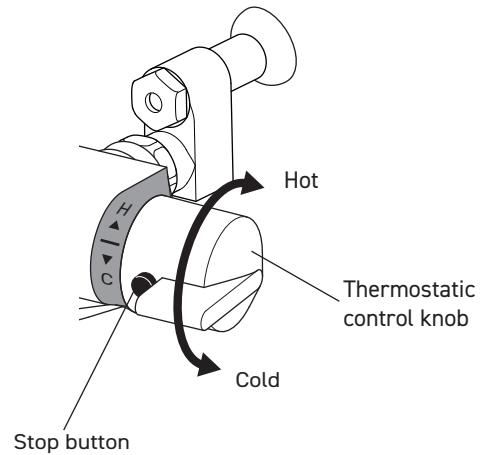

< DOUBLE TAP TYPE >

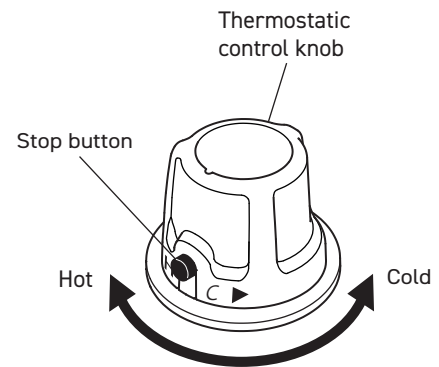

WARNING

- Check the temperature setting position of the thermostatic control before water is discharged. Hot water may discharge and cause burn. Do not operate the thermostatic control during the hair washing operation when washing the hair at a temperature higher than the thermostatic control lock position. There is a risk of scalding hot water on customer's head due to operation error.
- Return the thermostatic control to an appropriate position after use. Continuing to use the hot water with the thermostatic control in the hot position may cause burns.



CAUTION

- When adjusting the water temperature, reduce the volume of water, point the shower head away from the customer and check the temperature by hand. Take care when doing so, as hot water may come out of the shower head.
- Operate the tap only after removing metallic objects, such as rings and wristwatches. Failure to take this precaution may result in contact between the metal and the tap resulting in scratches or cracks on the plated surface and thereby causing peeling of the plating.
- Before using the product, check that there are no scratches, cracks, or peeling of the plated surface of the tap. If the plating is peeled off, immediately stop using the product and contact your local Takara Belmont dealer. Continued operation may result in personal injury.

Note

- When you turn the thermostatic control knob, the flow and temperature of the water may greatly change depending on the operating environment and conditions, but this is not a product fault. Causes of such a change are the supply of hot water outside the recommended temperature range (60°C–80°C), high pressures of cold and hot water supplies, a significant difference in pressure between cold and hot water supplies, and simultaneous use of multiple devices.
- Depending on the operating environment and conditions, the water temperature may not reach 40°C (a rough guide of a suitable level), although the thermostatic control knob is set in the lock position, but this is not a fault. This temperature lock system is an auxiliary safety function that prevents an abrupt flow of scalding water due to erroneous operation.
- Contact your local Takara Belmont dealer for adjustments to the hot water supply temperature, cold/hot water supply pressures, and lock position of the thermostatic control knob.

■ Filling the basin

When emulsifying hair dye, you can keep some water in the basin.

1. Slightly turn the drain cap to push it in.

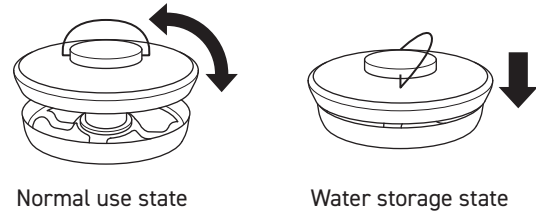

2. Turn on the tap to fill the basin.

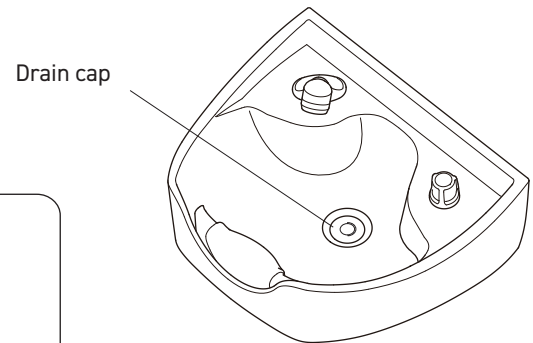

Note

A small amount of water may drain away. If the water level visibly drops, the drain cap gasket may be deteriorated or worn out, and needs replacing (available for a charge).



- The amount of water should be below the level shown by the dotted line in the illustration on the right (just below the shower hose slot).
- Do not leave the shower head in the water. Water may flow back when the water pressure in the water pipe decreases during a water outage.
- When the drainage speed slows, there is a possibility that dust and dirt may have clogged the drainpipe. Immediately stop using the product and contact your local Takara Belmont dealer.

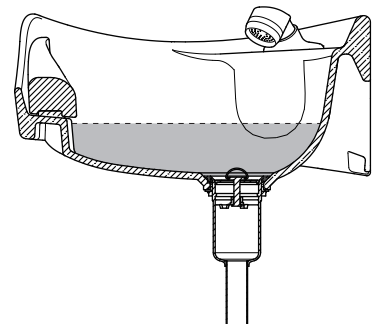

Guiding Customers

<When shampooing>

1. Instruct the customer to sit on the chair.
2. Put a shampoo cape on the customer, if necessary.

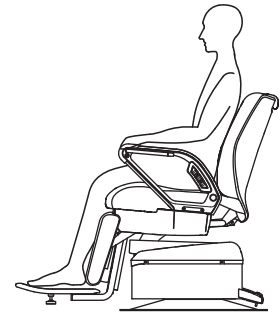

The following is a description of how to guide side shampoo.

3-1. Lay the customer down.

Reverse the chair, support the customer's head and place it gently onto the neck cushion.

If their face is not in a horizontal position, instruct the customer to slide forward or backward and make minor adjustments.

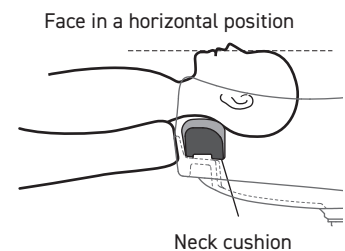

For details on how to operate the chair, please refer to the operation manual of the chair.



- Support the customer's head by hand when lowering the backrest. Failure to follow this instruction may cause the customer to hit its head on the basin.
- If the customer's neck does not fit comfortably on the neck cushion, do not provide a shampoo or any other service. Failure to follow this instruction may cause injury.



3-2. Provide a shampoo service etc.

Provide a shampoo service from the side of the basin.

4. After shampooing and other services

1. After shampooing and other services, get the customer up and return the chair to its original position.
2. After use, wipe off any water on the product.
 - Water on the outside surface of the basin.
 - Water dripping onto the floor via the shower hose.

In particular, when colouring material adheres, wipe immediately.

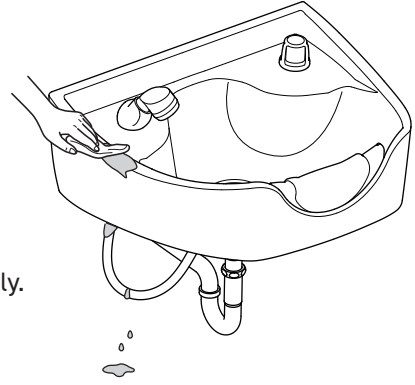

After use, wipe water away from all parts other than the basin. Leaving the unit with water on it may cause damage to the product.

Maintenance



Never use volatile chemicals, such as thinner, alcohol, remover, gasoline, and kerosene, acid, alkaline or chlorine-based detergents, antiseptic solution strongly corrosive to metals (Povidone Iodine, sodium hypochlorite, etc.), waxes containing abrading agent, sponges containing abrading agent and scrubbing brushes, or other cleaning tools.

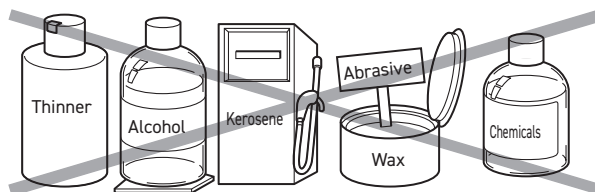

■ Basin

Wipe any dirt clean using detergent diluted with water.

If streaked scratches appear due to contact with metallic objects such as watch bands, rub the area with a nylon scourer.



Do not use a metallic scourer or sandpaper, as this will damage the basin.

■ Neck base

Wipe any dirt clean using detergent diluted with water. Carefully clean around the neck base with an item such as a cotton-tipped swab.

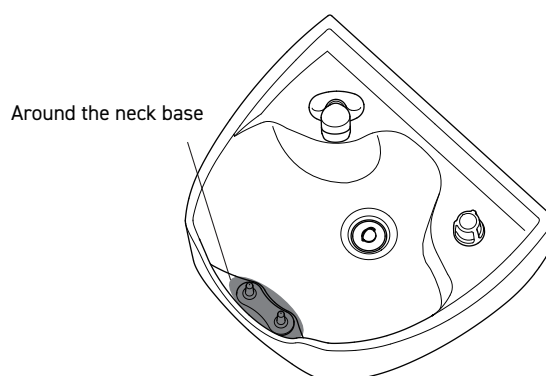

■ Drain cap

1 Wash the drain cap and the drain cap gasket in water to remove hair and dirt from the gap.

2 If it is difficult to remove dirt dilute a synthetic detergent with approx. ten parts of water and wipe off dirt.

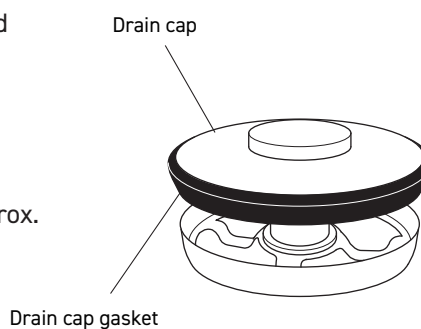

The drain cap is a consumable supply.

When water stored in the basin drains faster due to its deterioration etc., replace it (on a chargeable basis).

■ Hair catcher

1 Pull out the hair catcher located under the drain cap

2 Remove any hair that has been caught.



Be careful hair does not flow into the drainage pipe. Be careful not to let the hair flow into the drain pipe. It may clog the drain.

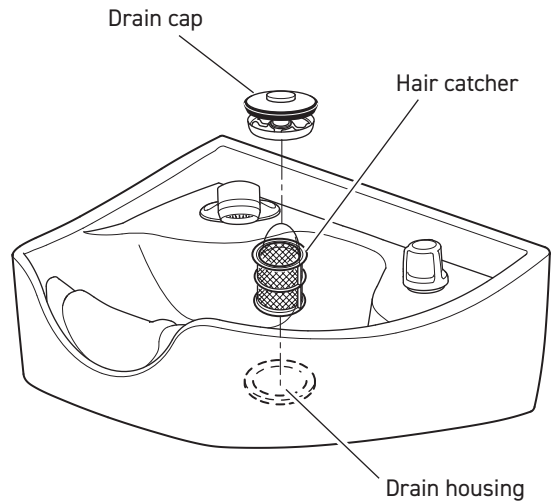

3 Install the hair catcher in the drain housing. (* Firmly push so it does not float.)



- Clean the hair catcher as regularly as possible. Continuing to use the hair catcher without cleaning can cause the drain to become blocked with hair, leading to water overflowing and unhygienic conditions. Try to clean the hair catcher after each shampoo.
- The hair catcher is a consumable supply. Replace the hair catcher if it is extremely dirty or the surface has deteriorated. (available for a charge)

■ Shower head holder, Tap, Thermostatic control

Wipe clean with a soft, dry cloth. If they are extremely dirty, wipe with detergent diluted with water, and always wipe them dry.



- Do NOT use sponges as even sponges intended for home use may damage the surface when used repeatedly.
- Do NOT use abrasives, sponges with abrasives, metal scrubbing brushes, nylon scrubbing brushes, etc., as they may damage the surface.
- Do NOT use chlorine-based, acidic, or any other heavy-duty chemical agents to clean the parts. Plating on the surfaces may peel.
- If you notice any peeling or scratches on the surface of the tap and any other parts, immediately stop using the product and contact your local Takara Belmont dealer. The peeling or scratched surface may injure your fingers.

■ Shower head

- 1 Turn the shower head plate to remove it; then, remove the rubber gasket.
- 2 Clean the shower head plate (with water).
 - With a toothbrush, scrape away any lime scale and dirt off the holes in the shower head plate.
- 3 Reassemble the shower head.
(Be careful to not forget the rubber gasket.)

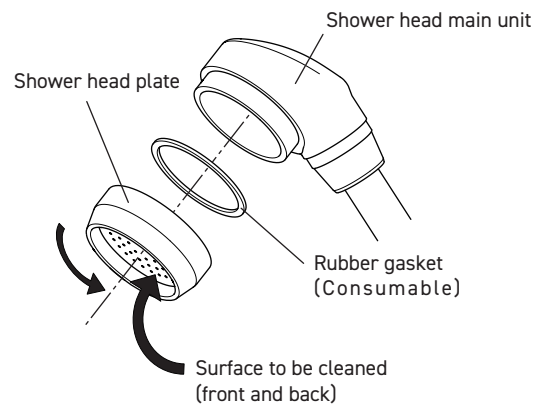

■ Neck cushion

- 1 At the end of the day, wash the neck cushion in water, wipe it dry with a towel, and let it dry in the shade.
- 2 If it is extremely dirty, wash with detergent diluted with the water, and rinse carefully with water.

The neck cushion is consumable supplies. Replace it if it is extremely dirty or the surface has deteriorated.
(available for a charge)

CAUTION

- If solvents drip onto the neck cushion, rinse with water as soon as possible. Failure to follow this instruction may cause deformation or discolouration.
- Clean the neck cushion every day. If left uncleaned, it may become mouldy.

■ Cleaning strainer

- 1 Lay some cloths (two or more towels) under the stop cock to catch drips of water.

CAUTION

- If there are electrical components such as wiring in the vicinity, be sure to prevent water from being splashed. Failure to observe this warning may result in electric leakage or fire.
- The hot water supply pipe or mixing pipe may become very hot. Do NOT touch the pipes directly.

- 2 Close the hot water and water stop valves.
Turn the stop cock clockwise with the supplied tool to close it.

! To prevent water leakage, always check that the stop valves are completely closed before cleaning or draining the water from the strainer.

- 3 Turn the strainer counterclockwise with the supplied tool to remove it.

CAUTION

Removing the strainer from the hot water supply pipe may cause hot water to spill out. Take extra care when draining the hot water.

- 4 Remove dust caught in the mesh of the strainer with a brush, etc.

- 5 Put the strainer back in place, firmly tighten it, and turn the stop cock anti-clockwise to open it.

- 6 Wipe off spilled water and remove the laid cloth.

CAUTION

Tighten the strainer firmly. If the tightening is loose, water may leak.

< SINGLE TAP TYPE >

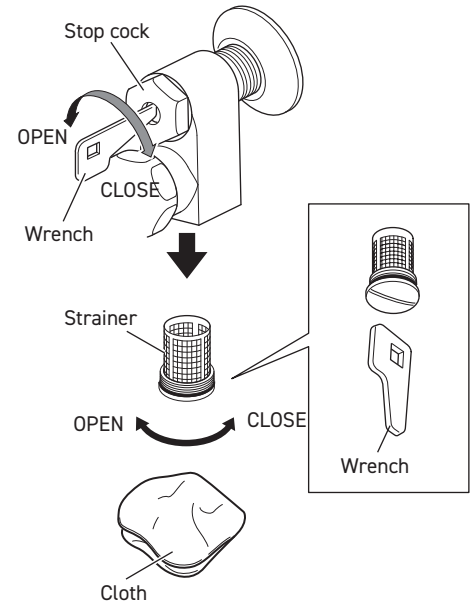

< DOUBLE TAP TYPE >

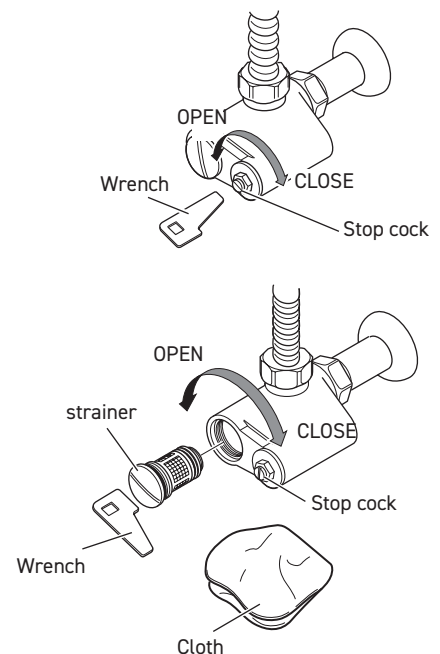

Daily Inspections

● To ensure that this product can be used for a long period of time, follow the procedures outlined in "Daily Check Guide" on page 24 to 25 of this instruction manual.



Always inspect this product following the procedures outlined in "Daily Check Guide". Continuing to use this product without performing the daily inspections may cause malfunctions or accidents.

Standard Duration of Use

The standard period of use of this product is seven years.

The standard period of use is "a guide for the standard period that this product can be used properly from a safety perspective, when conducting appropriate maintenance and inspections (including replacement of parts) for the standard usage conditions for each product.

This is not the same as the warranty period.

Before Requesting Repairs

If the following problems arise, conduct the checks outlined before requesting repairs.

Symptom	Check this	Solution
● Hot water will not come.	→ Is the main valve of the water pipe open?	Open the main valve of the water pipe.
	→ Is the stop valve open?	Open the stop valve.
● A noise is heard while the water is running.	→ Does turning the tap to change the flow rate affect the noise?	Run the water with a controlled flow rate. (See Note on page 11.)
● Water is tepid.	→ Is the water heater set to an appropriate temperature?	Set the water heater to the appropriate temperature.
	→ Is the thermostatic control set to an appropriate temperature?	Adjust the thermostatic control to an appropriate temperature. (See page 12.)
● Drainage condition is bad.	→ Is hair clogging the hair catcher?	Remove the hair clogging the hair trap. (See page 17.)
● The basin is smelly.	→ Is the basin dirty?	Wipe off the dirt.

If the product does not operate properly after checking and repairing the above points, stop using the product immediately.

Consumables

The following parts are "consumable supplies" and wear, degradation, changes in external appearance and damage are expected.

Please note that repair or replacement of these parts is not covered by warranty, and a fee will be required. (* The level and period of wear, degradation or damage may differ depending on the environment and conditions that the customer uses this product in.)

Inspections or replacement of parts will be required if there is extensive wear, degradation or damage.

Consumable Parts

(The following parts are not covered by the warranty; the cost of replacement is your responsibility.)

- | | | |
|--------------------------------------|---------------------------------------|---|
| <input type="checkbox"/> Drain cap | <input type="checkbox"/> Hair catcher | <input type="checkbox"/> Various rubber gasket |
| <input type="checkbox"/> Shower hose | <input type="checkbox"/> Neck cushion | <input type="checkbox"/> Lubricant (oil, grease, etc) |

Furthermore, scratches, contamination, deterioration, and discolouration of the exterior parts below are not to be covered by the warranty.

- External parts
 - Basin
 - Tap
 - Other parts (shower head, shower head holder, etc.).

Disposing of this Product

When disposing of this product or replaced parts, adhere with current regulations and dispose of them appropriately.

After-sales Service

To request after-sales service, contact your local Takara Belmont dealer.

Specifications

Part No.	Basin	EX-SB 1*[single tap type] EX-SB 2*[double tap type]
	Plumbing and fittings kit	AY-SB P1/P2 AY-SB S1/S2
External dimensions	See "Dimensions" on P23.	
Neck height	820	* In the case of the height from the floor to the basin holder is 750
Mixing method	Thermostatic control	
Output	Shower	
Output flow rate (with hot water pressure, water pressure: 0.14 MPa each)	Approximately 8.0L/min	
Stop valve	Single valve (with tap)	
Usage environment	Operating temperature of 10 to 40°C Operating humidity of 95% or less (ensure no condensation)	
* Hot-water supply temperature	80°C or below	
* Hot-water/water supply pressure	<ul style="list-style-type: none"> • Between 0.1 and 0.4MPa (1 to 4kgf/m³) • Water supply pressure \geq Hot-water supply pressure • Difference between hot-water supply pressure and water pressure: Within 0.2MPa (2kgf/cm²) 	
Weight	Basin unit	19.5 kg

Note: For details of the hot-water supply temperature, hot-water/water supply pressures, see the MAJOLICA PORTO Installation Instructions.

Product Dimensions

(unit : mm)

■ Top View (Single tap type)

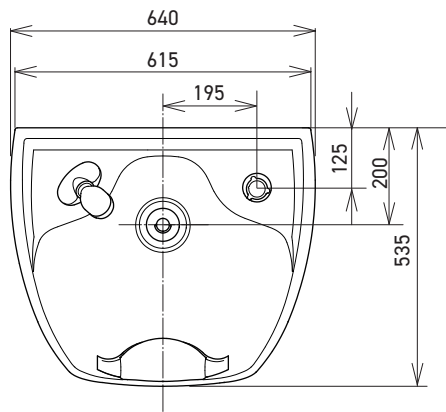

■ Top View (Double tap type)

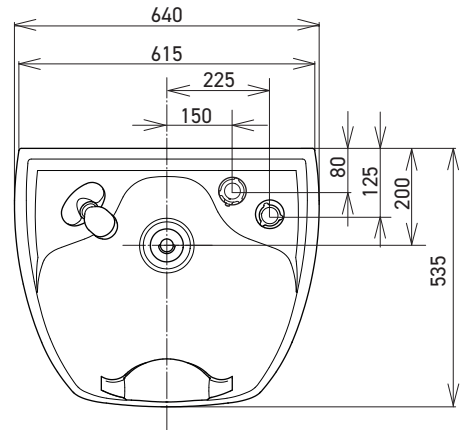

■ Front View (Single/Double tap type)

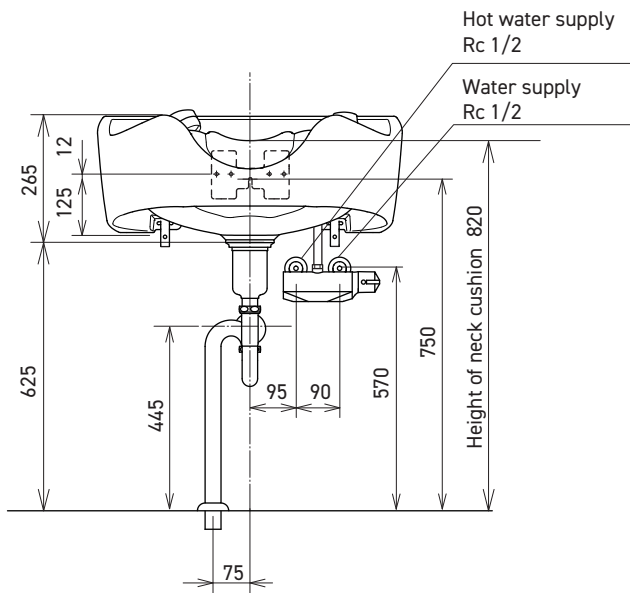

(Above picture is single tap type)

■ Side View (Single/double tap type)

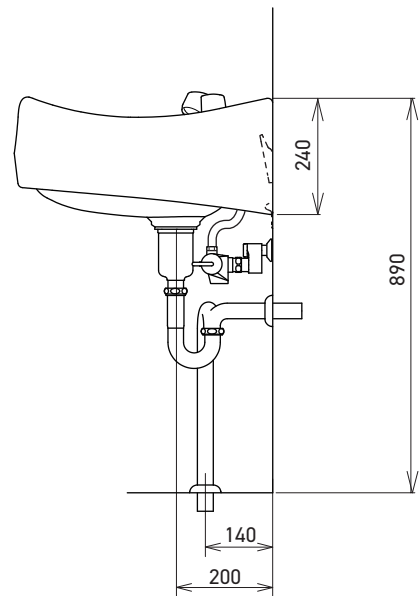

(Above picture is single tap type)

- ◆ The dimensions listed above may vary slightly from product to product.
- ◆ The height of neck cushion may vary slightly from product to product.

Daily Check Guide

To ensure that this product can be used for a long period of time, conduct the inspections below.

■ Inspect the product every day

Check item	How to check	If rejected as a result of checks
<input type="checkbox"/> Does the plating of the tap come off ?	<input type="checkbox"/> Check that there is no scratched, cracked or peeling plating on the tap or the thermostatic control knob. <input type="checkbox"/> While using and cleaning, check that the surface is smooth and that you do not feel or notice any changes.	<input type="checkbox"/> Scratches, cracks, or peeling of the plating may cause hand injuries.
<input type="checkbox"/> Is the basin steady ?	<input type="checkbox"/> Carefully push the front end of the basin, and check that there is steady.	<input type="checkbox"/> The basin may break or fall, leading to injury. Stop using the product and contact your local Takara Belmont dealer.
<input type="checkbox"/> Is the basin wet?	<input type="checkbox"/> Check that the outside surface of the basin is not wet.	<input type="checkbox"/> If left, the moisture may stain the surface or cause the product to break down. Wipe off water adhering to the outside surface of the basin immediately.
<input type="checkbox"/> Is the installation surface of the basin unit wet?	<input type="checkbox"/> Check that the area around the installation surface of the basin is not wet.	<input type="checkbox"/> If water is leaking from the pipe, the pipe, gasket or caulking may be worn, deteriorated or damaged. Close the stop valves in the water supply pipe and hot water supply pipe, and stop using the product immediately.
<input type="checkbox"/> Does the tap work properly?	<input type="checkbox"/> Turn on the tap and check that the water properly runs without making a strange noise. Turn off the tap and check that the water completely stops. You may hear a noise while the water is running. (See page 11.) <input type="checkbox"/> Turn on the tap and check whether the temperature is controlled properly and whether there is an unusual noise.	<input type="checkbox"/> If you hear a strange noise or turning off the tap does not completely stop the water, the tap may be defective. Contact your local Takara Belmont dealer. <input type="checkbox"/> In such a case where the temperature is not controlled properly or there is an unusual noise, the thermal parts may be defective.
<input type="checkbox"/> Does water come out from the shower head properly?	<input type="checkbox"/> Turn on the tap and check that the water comes through the shower head plate properly without leaking from the shower head plate or the base of the shower head and that the water is not cloudy.	<input type="checkbox"/> If water leaks from the shower head plate or the base of the shower head, the gasket or other inner parts may be worn out and need replacing. Contact your local Takara Belmont dealer. <input type="checkbox"/> If water does not come out properly or is cloudy, the strainer in the check valve may be dirty, so clean the strainer. (See page 20.) <input type="checkbox"/> If there are stray streams of water, the shower head plate may be clogged with lime scale or dirt, so remove the shower head plate and clean it. (See page 19.)

Check item	How to check	If rejected as a result of checks
<input type="checkbox"/> Is the drain cap blocked with hair etc? <input type="checkbox"/> Can the basin be filled with water? <input type="checkbox"/> Has the neck cushion deteriorated? <input type="checkbox"/> Is the caulking between the basin and the wall broken? <input type="checkbox"/> Is there an abnormal odor coming from the basin drain?	<input type="checkbox"/> Check that it is not clogged with hair or dirt. <input type="checkbox"/> Check that the drain cap can be used to block the drain and that water filling the basin does not drain. <input type="checkbox"/> Check that there is no tearing, dirt or sinking of the neck cushion surface. <input type="checkbox"/> Check that the caulking between the basin and the wall is not broken. Check that there is no water leakage from between the basin and the wall. <input type="checkbox"/> Check if there is an abnormal odor coming from the basin drain.	<input type="checkbox"/> Remove a buildup of hair etc. if it appears in the drain cap. <input type="checkbox"/> If the water filling the basin will drain quickly, first check that the gasket of the drain cap is correctly installed. If the problem persists, the drain cap gasket may be deteriorated. Replace it as soon as possible. <input type="checkbox"/> These may cause pain or transfer dirt to the customer's neck and head. The neck cushion is consumable supplies. Replace them as soon as possible. <input type="checkbox"/> There is a risk of damaging the floor and the wall. <input type="checkbox"/> Remove any hair and other objects trapped in the hair catcher. (See page 17.)

■ Always inspect the product after work every day

Check item	How to check	If rejected as a result of checks
<input type="checkbox"/> Is the drain blocked? <input type="checkbox"/> Is the tap completely turned off?	<input type="checkbox"/> Check that the drain is not blocked with the drain cap, towel or shampoo cloth. <input type="checkbox"/> Turn the taps firmly in a clockwise direction and check that the water turns off properly.	<input type="checkbox"/> Remove the object that is blocking the drain. If the drain is blocked, water that is turned on accidentally or a slight trickle of water due to an increase in water pressure at night may cause water to spill from the basin, leading to water leakage. <input type="checkbox"/> Turn the taps firmly and turn the water off properly. If the water does not turn off completely, there may be a malfunctions in the stop valves of the tap. Close the stop valves in the water supply pipe and hot water supply pipe, and stop using the product immediately.

■ Inspect the product once per week

Check item	How to check	If rejected as a result of checks
<input type="checkbox"/> Is there any lime scale or dirt on the shower head plate? <input type="checkbox"/> Is the drain housing or the trap leaking?	<input type="checkbox"/> Remove the shower head plate from the shower head and check that there is no lime scale or dirt on it. (See page 18.) <input type="checkbox"/> Check that neither the drain housing nor the trap is leaking.	<input type="checkbox"/> With a toothbrush, scrape away any lime scale and dirt off the shower head plate to clean it. Otherwise, the shower head plate may be clogged, and water may not flow through it. <input type="checkbox"/> If the drain housing or the trap is leaking, the gasket or caulking may be worn, deteriorated or damaged. Immediately stop using the product and contact your local Takara Belmont dealer for assistance.

Note

Note

 **TAKARA
BELMONT**
TAKARA BELMONT CORPORATION
1-1, 2-Chome, Higashi-shinsaibashi, Chuo-ku, Osaka, Japan
TEL: +81-6-6213-5945 FAX: +81-6-6212-3680

Book Number

1E07YHA0

Printed in Japan